

OPTIMIZATION AND SENSITIVITY ANALYSES OF A COMBINED COOLING, HEAT AND POWER SYSTEM FOR A RESIDENTIAL BUILDING

by

Filipi Maciel MELO^a, Eduardo Antonio PINA^b, and Monica CARVALHO^{a*}

^a Federal University of Paraiba, Joao Pessoa, Recife, Brazil

^b University of Zaragoza, Zaragoza, Spain

Original scientific paper

<https://doi.org/10.2298/TSCI200718335M>

In the quest for a better use of energy resources, energy integration, and cogeneration strategies have been employed in the industrial and commercial sectors with considerable benefits realized. However, the residential sector remains underexplored. An optimization procedure should be carried out whenever there is a need to ensure or verify the economic viability of an energy system. This study uses Mixed Integer Linear Programming to optimize the energy supply to a residential building, with 20 floors and 40 apartments, located in the city of Joao Pessoa (northeast Brazil). The equipment available includes gas engines, electric and natural gas boilers, heat exchangers, cooling towers, and absorption and mechanical chillers. The optimization establishes the optimal system configuration and operational strategy (operation throughout the year). Economic, technical, and legal aspects were considered in the minimization of the total annual costs associated with the building's energy supply. The energy demands were calculated on an hourly basis, throughout one year, by the EnergyPlus software and corresponded to hot water (83 MWh per year), electricity (171 MWh per year), and cooling (242 MWh per year) demands. The optimal system was entirely reliant on the electric grid to meet the electricity demand directly and to satisfy heating and cooling demands by means of an electric hot water boiler and a mechanical chiller. The optimal solution is tested by varying, within reasonable limits, selected parameters: natural gas and electricity tariffs, the behavior of residents, amortization factor, and relationship between the tariffs of electricity and natural gas.

Key words: optimization, mixed integer linear programming, energy, building, residential, sensitivity analysis, northeast Brazil

Introduction

The increase in life quality standards resulting from people's search for comfort and well-being translates into higher energy services demands, which, in the residential sector, typically consist of electricity, heating (domestic hot water and space heating), and cooling [1]. Energy demands are influenced by geographic location, climate conditions, cultural habits, architectural characteristics, to name a few. In Brazil, where climate conditions are generally characterized by warm summers and mild winters, energy demands are quite different from those of European countries, with lower heating and higher cooling demands. Moreover, the size of the building and its geographic location directly influence the consumption of heating and cooling due to the space that must be acclimatized and the heat transfer area.

* Corresponding author, e-mail: monica@cear.ufpb.br

According to Brazil's Energy Research Office, in 2017, the buildings sector (residential, commercial, and public buildings) accounted for 51% of the electricity consumed in the country. Residential buildings alone were responsible for 26% of the total electricity consumption [2]. In the last decade, electricity consumption in the residential sector has increased from 100.6 GWh in 2009 to 136.2 GWh in 2018 [3]. The estimated electricity consumption for air conditioners in Brazil represents about 15% of the electricity use in residential buildings [2], in contrast to 50% in developed countries [4].

In northeast Brazil, residential-commercial buildings have been the focus of the environmental and economic optimizations presented by Carvalho *et al.* [5] and Delgado *et al.* [6], respectively. A bicriteria synthesis and optimization was presented by Carvalho *et al.* [7] for the city of Joao Pessoa.

Brahman *et al.* [8] developed an optimization model for the electrical and thermal energy management of a residential energy hub, integrating demand response and energy storage. Esther and Kumar [9] reported on residential demand-side management architecture, approaches, optimization models, and methods, and Lauinger *et al.* [10] presented a linear programming approach to the optimization of residential energy systems. The MILP-based optimization models for energy supply systems were applied to residential buildings located in northern Spain by Iturriaga *et al.* [11] and central Europe by Szykowski *et al.* [12]. Abbasi *et al.* [13] optimized the design of a power system for a residential building considering its application in various climatic regions. The multi-purpose model was adopted, taking into account the energetic, economic, and environmental aspects. Zheng *et al.* [14] developed a multi-purpose optimization model to identify the best design to meet the energy demands of tertiary buildings.

The main contribution of this study is the application of an established and scientifically-verified optimization method to the residential sector, considering the tropical climate of northeastern Brazil. This study presents the calculation of energy demands, and then synthesizes and optimizes the energy supply system for a residential building, located in the city of Joao Pessoa (northeast Brazil). The software employed are EnergyPlus [15] and Lingo [16]. Economic, legal, and geographic aspects of the site are taken into account. This work contributes to the energy development of the residential sector by providing information that assists in decision making, such as the technologies that will be used to meet energy demands and how these technologies will operate throughout the day and throughout the year. Sensitivity analyses show how the optimal solution supports future technical and economic uncertainties (*e.g.*, changes in energy demands, amortization and maintenance costs, gas prices).

Methodology

Energy demands

EnergyPlus [15] was utilized to simulate the residential building and calculate its energy demands, considering the location of Joao Pessoa (latitude -7.11° , longitude -34.86°). The program calculates the hourly demands for every day of the year. The building simulated had 20 floors, each floor with two 92 m² apartments. The size and internal distributions of the apartments were selected based on average, middle-income apartments of Joao Pessoa. Local climate data was obtained from the National Association of Built Environment Technology, recorded by the weather stations of the Brazilian National Institute of Meteorology [17], and included ambient air temperature, relative humidity, dew point temperature, atmospheric pressure, wind speed, rain and global irradiance. The study extended over one year. Due to the characteristics of the building's energy demands, which vary each month according to weather conditions and are similar between weekdays and between weekends, two representative days per month were

considered (one weekday and one weekend, totaling 24 days per year). Each representative day was divided into 24 hourly periods, which yielded 576 time intervals per year.

A file with extension.dxf is generated from the modelling of the building's walls, doors, and windows. Figure 1 shows a modification of the generated dxf file and depicts the floor plan. The building materials of the walls, doors, and windows were, respectively, concrete, wood, and glass, with properties shown in tab. 1, where ρ is the specific mass, k – the conductivity, and c – the specific heat, the values were obtained by NBR 15220 [18]. It must be highlighted that these construction materials are standard practice in northeast Brazil and that insulation is not used, although the benefits associated with insulation could further reduce energy consumption (mostly related to air conditioning) and associated costs.

Figure 1. Generic floor of the building:

- 1 – laundry room (A), 2– bedroom (A),
- 3 – kitchen (A), 4 – bathroom (A),
- 5 – en-suite bedroom (A), 6 – en-suite bedroom (A),
- 7 – living room (A), 8 – balcony (A),
- 9 – balcony (A), 10– living room (B),
- 11 – en-suite bedroom (B), 12 – bathroom (B),
- 13 – en-suite bedroom (B), 14 – bedroom (B),
- 15 – kitchen (B), 16 – laundry room (B)

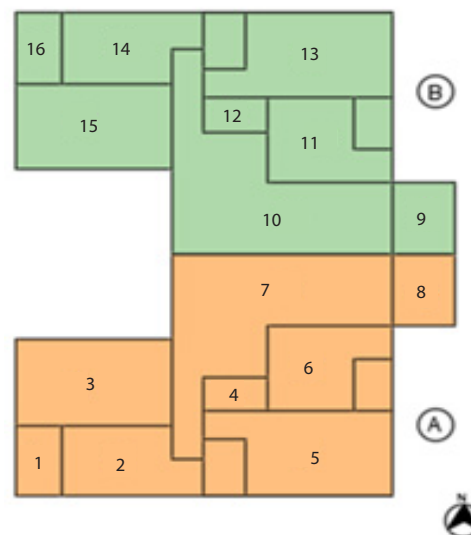

Table 1. Properties of the building materials for the walls, doors and windows

Material	ρ [kgm ⁻³]	k [Wm ⁻¹ K ⁻¹]	c [kJkg ⁻¹ K ⁻¹]
Normal concrete	2200-2400	1.75	1.00
High density fiberboard	800 – 1000	0.29	1.34
Common glass	2500	1.00	0.84

The cooling load is calculated by the software, for all days throughout the year, from the selection of a *comfort* temperature for the thermostat of the refrigeration system and identification of the zones that will be acclimatized by the system. The *comfort* temperature was set at 22 °C (following common practice in northeast Brazil) for zones 2, 5, 6, 11, 13, and 14 (bedrooms and en-suite bedrooms). This means that between 00:00 and 09:00 hours, the maximum temperature in those locations is 22 °C.

The internal loads, lights, and electrical equipment followed tab. 2, which employed real data from commercially-available appliances and assumptions on the domestic utilization of equipment. The technologies displayed in tab. 2 operate during representative days without distinction throughout the year (during the indicated hours of operation), except for the washing machine, which is limited to Saturdays and Sundays throughout the year.

Table 2. Equipment and lighting usage data (for one apartment)

–	Lighting	Television	Refrigerator	Washing machine	Dishwasher
Quantity	-	3	1	1	1
Power	5 W/m ²	90 W	200 W	450 W	1500 W
Operation	Daily	Daily	Daily	Weekends	Daily
Use load	25%	30%	50%	100%	100%
Start of operation	17:00 hour	10:00 hour	00:00 hour	09:00 hour	20:00
End of operation	18:00 hour	14:00 hour	00:00 hour	16:00 hour	22:00
Use load	100%	100%	–	–	–
Start of operation	18:00 hour	18:00 hour	–	–	–
Start of operation	00:00 hour	00:00 hour	–	–	–

Regarding hot water, 45 °C was considered as the desired temperature. It was considered that the water supplied by the grid was in thermal equilibrium with the ambient air temperature. Daily consumption of hot water was assumed to be 60 liters per person, where each apartment housed four people, resulting in a consumption of 240 liters per apartment. Consumption of hot water was limited to two hours a day, from 7:00 to 8:00 and from 21:00 to 22:00, for all representative days, throughout the year.

Equipment

There are two major approaches to synthesize an energy system:

- the problem can be solved by decomposition and heuristic rules, and
- simultaneous optimization using mathematical programming [19].

While the first procedure is simple, it can lead to sub-optimal designs. The second strategy requires creating a superstructure that includes equipment that cover all possible processes and connections. According to Yeomans and Grossmann [19], equipment models and their connectivity, along with operational constraints, are incorporated into a mathematical model, where an objective function is specified. Once the system is optimized, this superstructure is reduced to its optimal configuration. Therefore, the superstructure must include all equipment and flows that may be part of an optimum configuration, allowing several possible alternatives for each process. The superstructure of an energy system for the specific residential northeast Brazil building counts with the possibility of installing equipment such as GNVA (natural gas steam boiler), EEVA (electric steam boiler), GNAQ (natural gas hot water boiler), EEAQ (electric hot water boiler), MGAQ (gas engine + hot water heat recovery unit), TCVA (steam-hot water heat exchanger), TCAQ (hot water-cooling water heat exchanger), FAAQ (single-effect absorption chiller), FMAR (mechanical chiller), and ICAR (cooling tower, to evacuate heat). The energy utilities available are GN (natural gas), VA (steam, 180 °C), AQ (hot water, 90 °C), AR (cooling water, $t_0 + 5$ °C), AA (ambient air, t_0), AF (chilled water, 5 °C), and EE (electricity).

Figure 2 shows the superstructure of energy system: C represents the utilities that can be purchased from the market (imports), V represents the exports (considering legal aspects and regulations), D represents the energy demands of the building, and P represents losses to the environment (herein only evacuated heat was considered). The technologies that produce residual heat reject that heat at $t_0 + 5$ °C to the AR, through a heat exchanger (TCAQ). This heat must be dissipated to the ambient air temperature, t_0 , by the cooling tower (ICAR). In the case

of the gas engine + hot water heat recovery unit (MGAQ), a small portion of the heat generated is dissipated to the AR utility, without the use of a heat exchanger (TCAQ), at a low temperature, as the largest portion of the heat generated by MGAQ is used in the AQ utility at 90 °C.

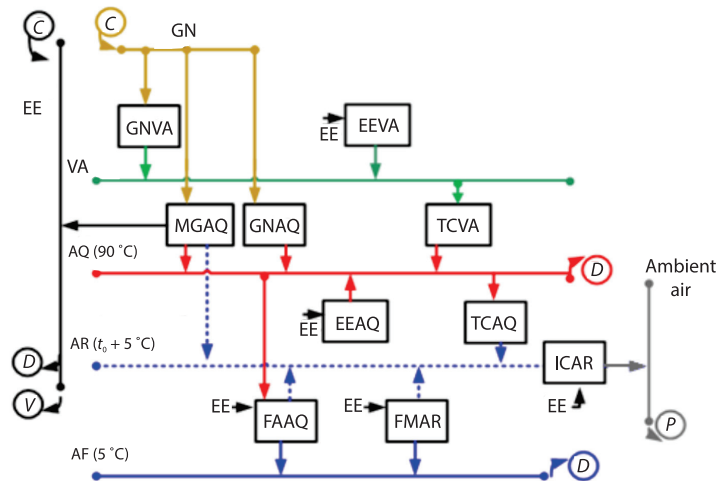

Figure 2. Superstructure of the energy system

The candidate technologies in the superstructure consist of real, commercially available devices, whose nominal power capacities were carefully selected based on the building's energy demands that were simulated in EnergyPlus. Table 3 presents technical and economic data of the equipment. Technical data and costs were obtained from consultations with manufacturers and based on Delgado *et al.* [6]. The rows indicate the potentially installable technologies, while the columns indicate the energy utilities available. The production coefficients in bold represent the flow that defines the capacity of the equipment. Positive coefficients indicate that utility is produced, and negative coefficients indicate the consumption of that utility. The C_{INV} is the capital cost of the equipment, and P_{NOM} is the nominal power of the equipment.

Table 3. Technical, production, and financial data of equipment

	GN	VA	AQ	AR	AA	AF	EE	C_{INV} (10^3 BRL \$)	P_{NOM} [kW]
Gas engine, MGAQ	-3.06		1.77	0.1			1	175.74	108
Steam boiler, GNVA	-1.24	1						54.00	116
Steam boiler, EEVA		1					-1.15	42.50	150
Heat exchanger, TCVA		-1.10	1					3.35	150
Hot water boiler, GNAQ	-1.12		1					49.30	300
Hot water boiler, EEAQ			1				-1.11	28.20	150
Heat exchanger, TCAQ			-1.10	1				3.00	150
Absorption chiller, FAAQ			-1.36	2.36		1	-0.01	342.78	350
Mechanical chiller, FMAR				1.24		1	-0.24	102.25	180
Cooling tower, ICAR				-1.00	1		-0.02	5.00	180

Electricity and natural gas tariffs

In Brazil, electricity is regulated by the Brazilian Electricity Regulatory Agency (ANEEL), responsible for supervising and co-ordinating the production, transmission, and commercialization of electricity. The residential building was classified under group B of normative resolution n° 414/2010 [20], issued by ANEEL, with a flat tariff equal to $PEE = 442$ BRL/MWh (including taxes) [21].

Regarding natural gas, there are eight tariff classes available for the residential sector: herein, an average consumption of 100-200 m³ per month was estimated, which corresponds to the Class 4 tariff of $PGN = 322$ BRL/MWh (including taxes) [22].

Legal scenario

In Brazil, ANEEL established the general conditions for distributed microgeneration and minigeration access to electricity distribution systems and to the Electric Energy Compensation System through Normative Resolutions 482/2012 [23] and 687/2015 [24]. The Energy Compensation System enables consumers to install small generators that use incentivized energy sources (hydro, solar, biomass, qualified cogeneration and wind) and exchange electricity with the local distributor [23, 24] the surplus electricity is exported into the electric grid, generating credits to offset the consumption of succeeding months.

Mathematical model

The mathematical optimization model was based on MILP and solved by LINGO software [16], a specialized optimization solver. The objective function considered the minimization of total annual costs, which encompass fixed costs (equipment, CFI) and variable costs (energy costs, CVA). The objective function can be represented, in simple algebraic language:

$$\text{minimize total annual cost} = CFI + CVA \quad (1)$$

The annual fixed costs, CFI , are expressed by eq. (2), where FAM is the amortization factor, i refers to the type of technology, $TEC(i)$ is the number of i technologies installed, and $C_{INV}(i)$ is the individual capital cost. The variable costs, CVA , are expressed by eq. (3), where $COM(d, h, GN)$ is the purchase of natural gas in the period (d, h) , $COM(d, h, EE)$ is the purchase of electricity in the period (d, h) , $VEN(d, h, EE)$ is the export of electricity in the period (d, h) . The PGN and PEE are the prices of natural gas and electricity, respectively. Electricity exports to the grid are accounted as credits, discounted in future bills:

$$CFI = (FAM) \left[\sum TEC(i) C_{INV}(i) \right] \quad (2)$$

$$CVA = \sum_{d,h} \left[COM(d, h, GN) PGN + COM(d, h, EE) PEE - VEN(d, h, EE) PEE \right] \quad (3)$$

The amortization factor (FAM) is equal to the capital recovery factor (CRF) plus a maintenance and operating factor (FMO) for the system:

$$FAM = CRF + FMO \quad (4)$$

The FMO was considered to be equal to 7% of the capital costs of the system ($FMO = 0.07 \text{ year}^{-1}$). The CRF considers the interest rate, iy_r , and the lifetime of equipment, ny_r :

$$CRF = iy_r \frac{(1 + iy_r)^{ny_r}}{(1 + iy_r)^{ny_r} - 1} \quad (5)$$

For the current economic scenario of Brazil, an interest rate of 10% per year and equipment lifetime of 15 years were considered ($CRF = 0.13 \text{ year}^{-1}$). Thus, the resulting FAM value considered herein was equal to 0.20 year^{-1} .

The possibilities of interaction between the system and the economic market can be represented by a binary matrix (0 = no, 1 = yes) with indicators for the possibilities of purchase, $YUP(j)$, demand, $YUD(j)$, exports, $YUS(j)$, and waste, $YUW(j)$, for each available energy resource j , tab. 4.

Table 4. Matrix of possibilities of system interactions

Utility j	$YUP(j)$	$YUD(j)$	$YUS(j)$	$YUW(j)$
Natural gas, GN	1	0	0	0
Steam, VA	0	1	0	0
Hot water, AQ	0	1	0	0
Cooling wate, AR	0	0	0	0
Ambient air, AA	0	0	0	1
Cold water, AF	0	1	0	0
Electricity, EE	1	1	1	0

The operation of the system is subject to capacity limits, production constraints, and balance equations. For each type of technology i , the total installed power, $PIN(i)$, is equal to the number of installed equipment, $TEC(i)$, multiplied by the nominal power, $P_{NOM}(i)$, of each piece of equipment, eq. (6). For each time interval, $PRO(d, h, i)$, refers to the total production of the set of technologies i , on a given day, d , and hour, h , and is restricted to the installed capacity of the equipment, eq. (7):

$$PIN(i) = TEC(i) P_{NOM}(i) \quad (6)$$

$$PRO(d, h, i) \leq PIN(i) \quad (7)$$

The energy flow of utility j produced or consumed from technology i , $X(i, d, h, j)$ is expressed by eq. (8), where $K(i, j)$ is the absolute value of the production coefficients of tab. 3:

$$X(i, d, h, j) = K(i, j) PROD(d, h, i) \quad (8)$$

Energy balances must also be fulfilled:

$$COM(d, h, j) + PRO(d, h, j) - CON(d, h, j) - DEM(d, h, j) - VEN(d, h, j) - PER(d, h, j) = 0 \quad (9)$$

$$PRO(d, h, j) = \sum X(i, d, h, j) YTUP(i, j) \text{ with } YTUP(i, j) \in \{0, 1\} \quad (10)$$

$$CON(d, h, j) = \sum X(i, d, h, j) YTUC(i, j) \text{ with } YTUC(i, j) \in \{0, 1\} \quad (11)$$

$$COM(d, h, j) \leq YUP(j) [CON(d, h, j) + DEM(d, h, j)] \text{ with } YUP(j) \in \{0, 1\} \quad (12)$$

$$VEN(d, h, j) \leq YUS(j) PRO(d, h, j) \text{ with } YUS(j) \in \{0, 1\} \quad (13)$$

$$PER(d, h, j) \leq YUW(j) PRO(d, h, j) \text{ with } YUW(j) \in \{0, 1\} \quad (14)$$

$$DEM(d, h, j) \leq YUD(j) [PRO(d, h, j) + COM(d, h, j)] \text{ with } YUD(j) \in \{0, 1\} \quad (15)$$

where $COM(d, h, j)$, $PRO(d, h, j)$, $CON(d, h, j)$, $DEM(d, h, j)$, $VEN(d, h, j)$, and $PER(d, h, j)$ are, respectively, the purchase, production, consumption, demand, sale, and loss of utility j in the period (d, h) , $YTUP(i, j)$ and $YTUC(i, j)$ are input data and are binary variables. The $YTUP(i, j)$ will be 1 when technology i produces utility j , as shown in tab. 5. The $YTUC(i, j)$ will be 1 when technology i consumed utility j , as shown in tab. 6. Production (PRO) and consumption (CON) correspond to internal energy flows. Purchase (COM), sale/exports (VEN), loss (PER), and demand (DEM) correspond to energy flows exchanged between the energy system and the environment. Binary variables $YUP(j)$, $YUS(j)$, $YUW(j)$, and $YUD(j)$, respectively, indicate the possibility of such exchanges, according to tab. 5.

Table 5. Input data $YTUP(i, j)/YTUC(i, j)$

j/i	MGAQ	GNVA	EEVA	TCVA	GNAQ	EEAQ	TCAQ	FAAQ	FMAR	ICAR
GN	0/1	0/1	0/0	0/0	0/1	0/0	0/0	0/0	0/0	0/0
VA	0/0	1/0	1/0	0/1	0/0	0/0	0/0	0/0	0/0	0/0
AQ	1/0	0/0	0/0	1/0	1/0	1/0	0/1	0/1	0/0	0/0
AR	1/0	0/0	0/0	0/0	0/0	0/0	1/0	1/0	1/0	0/1
AA	0/0	0/0	0/0	0/0	0/0	0/0	0/0	0/0	0/0	1/0
AF	0/0	0/0	0/0	0/0	0/0	0/0	0/0	1/0	1/0	0/0
EE	1/0	0/0	0/1	0/0	0/0	0/1	0/0	0/1	0/1	0/1

As a result, the model provides all the energy flows of the optimal system, the number of equipment installed for each technology, $TEC(i)$, the fixed and variable costs, and total annual costs of the optimal system.

Results and discussions

Energy demands

Table 6 shows the energy demands calculated by EnergyPlus, where w refers to weekdays and f refers to weekends and holidays. Energy demands were calculated on an hourly basis, for two representative days per month, throughout one year. There is only a slight variation in the electricity demand between weekdays and weekends, as it was considered that the washing machine would only be used on weekends and holidays. The hot water demand depended on the external air temperature, which varies seasonally. The need for refrigeration (air conditioning) varies every day, depending on the external air temperature. Figure 3 depicts the energy demands for the representative days considered in January and August.

Optimization

The solution of the optimization model provides the configuration of the energy system and its operational strategy throughout one operational year. Firstly, the model was solved in a constrained manner, obtaining a reference system, in which demands were met traditionally (the model did not allow the installation of the cogeneration module nor of the absorption chiller). Then model was freely solved, enabling the possibilities of cogeneration and trigeneration and electricity exports, to obtain the optimal economic solution. When solving this model, 74586 variables were present, of which 596 were integers. The model presented 56146 interactions. The results are shown in tab. 7.

The optimal economic system presented the same configuration and operation of the reference system. For the case study herein presented, the minimum total annual cost was ob-

Table 6. Energy demands for each representative day

Representative day	Number of days/year	Electricity	Hot water	Cooling
		Total [kWhday ⁻¹]	Total [kWhday ⁻¹]	Total [kWhday ⁻¹]
January, <i>w</i>	20	451.96	211.19	989.12
January, <i>f</i>	11	497.68	206.60	1047.63
February, <i>w</i>	19	451.96	200.84	905.26
February, <i>f</i>	9	497.68	205.08	963.21
March, <i>w</i>	20	451.96	194.44	1112.81
March, <i>f</i>	11	497.68	200.35	1111.51
April, <i>w</i>	20	451.96	219.05	542.76
April, <i>f</i>	10	497.68	223.22	793.03
May, <i>w</i>	20	451.96	223.29	590.77
May, <i>f</i>	11	497.68	212.93	607.82
June, <i>w</i>	19	451.96	236.98	385.45
June, <i>f</i>	11	497.68	226.00	321.20
July, <i>w</i>	20	451.96	231.00	221.92
July, <i>f</i>	11	497.68	236.57	249.04
August, <i>w</i>	20	451.96	247.34	314.79
August, <i>f</i>	11	497.68	236.57	226.80
September, <i>w</i>	21	451.96	218.56	449.82
September, <i>f</i>	9	497.68	220.72	409.47
October, <i>w</i>	20	451.96	213.21	745.91
October, <i>f</i>	11	497.68	215.99	695.51
November, <i>w</i>	20	451.96	211.96	889.70
November, <i>f</i>	10	497.68	217.73	807.72
December, <i>w</i>	20	451.96	207.37	1042.32
December, <i>f</i>	11	497.68	223.43	931.92
Σ		MWh per year	MWh per year	MWh per year
Year	365	171	83	242

tained with the installation of an electric hot water boiler and a mechanical chiller that consumed electricity from the grid to satisfy the heating and cooling demands, and direct purchase of electricity from the grid met the electricity demands. Thus, the results indicate that electricity consumption from the grid is economically advantageous, excluding natural gas from the optimal solution and the possibility of co- and tri-generation.

Furthermore, for the northeast Brazil scenario, with high average ambient temperatures throughout the year, there are low heating demands (only related to hot water for showers), rendering cogeneration unfeasible from an economic viewpoint. Usually, a cogeneration system is designed in function of the thermal demand. Electricity production can be lower or higher than the electricity demand, which opens the possibility of exporting electricity to the

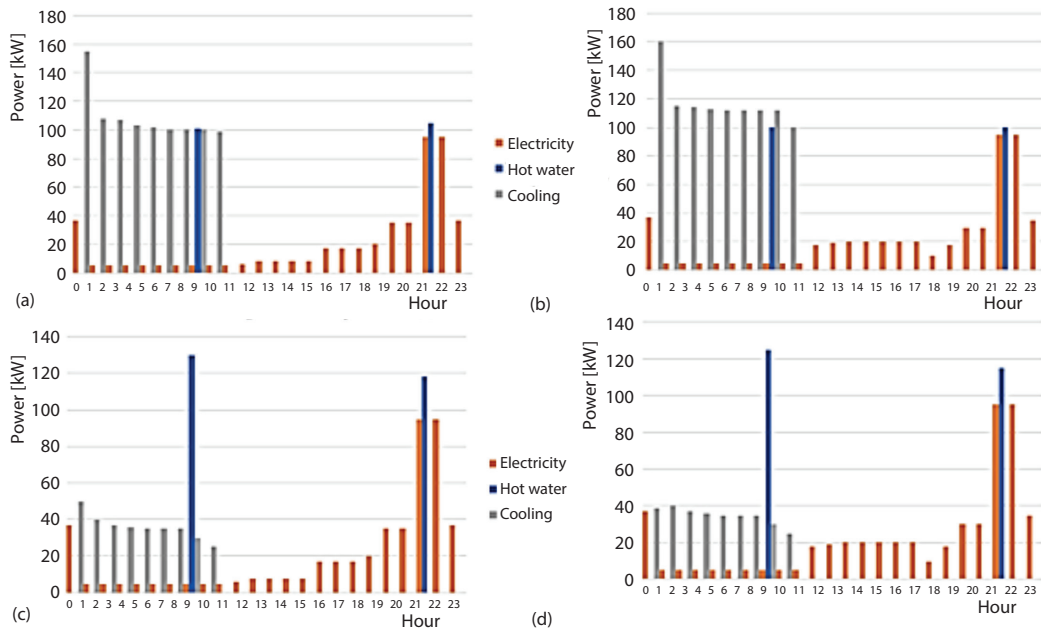

Figure 3. Energy demands for a representative day in January; (a) weekday and (b) weekend and a representative day in August; (c) weekday and (d) weekend

Table 7. Reference and optimal economic systems

System composition	Reference system		Optimal economic	
	Number	Power installed	Number	Power installed
Gas engine	–	0	0	0
Steam boiler, GN	0	0	0	0
Hot water boiler, GN	0	0	0	0
Steam boiler, EE	0	0	0	0
Hot water boiler, EE	1	150 kW	1	150 kW
Heat exchanger, VA->AQ	0	0	0	0
Heat exchanger, AQ->AR	0	0	0	0
Absorption chiller	–	0	0	0
Mechanical chiller	1	180 kW	1	180 kW
Cooling tower	2	360 kW	2	360 kW
Natural gas consumption	0		0	
Purchase of electricity	308 MWh _{year} ⁻¹		308 MWh _{year} ⁻¹	
Electricity credits	–		0	
Fixed costs	32,303 BRL\$ _{year} ⁻¹		32,303 BRL\$ _{year} ⁻¹	
Variable costs	136,048 BRL\$ _{year} ⁻¹		136,048 BRL\$ _{year} ⁻¹	
Total annual cost	168,351 BRL\$ _{year} ⁻¹		168,351 BRL\$ _{year} ⁻¹	

grid. In the residential building considered herein, the hot water demand was relatively low. Still, the refrigeration demand was high, which could justify trigeneration if the tariff of natural gas and the investment cost of the absorption chiller were more advantageous than the electricity and the mechanical chiller, respectively.

Sensitivity analyses

Based on the analyses presented by [25-27], the sensitivity analyses developed herein aimed to assess how optimal decisions are affected by information updates on demands and economic factors. Thus, the values of the following parameters were varied: natural gas and electricity tariffs, the amortization factor, energy services demands, and comfort habits (residents of the building began utilizing air conditioning for 12 hours a day).

The natural gas tariff was reduced by 10%, 20%, and 30%. Relative to the optimal cost solution presented in section *Optimization*, with a 10% reduction in the natural gas tariff, natural gas hot water boilers became advantageous, replacing the hot water electric boiler, as shown in tab. 8. Lowering the natural gas tariff further resulted in the same system configuration, which suggests that a more dramatic decrease would have to take place to render cogeneration economically feasible. When the natural gas tariff was increased, its use only became less advantageous and did not alter the solution of the optimization model.

Table 8. Optimal economic results considering changes in the tariff of natural gas

	-30%	-20%	-10%	Optimal economic (base)
System composition	Number of equipment/ Power installed, [kW]			
Gas engine	0/0	0/0	0/0	0/0
Steam boiler, GN	0/0	0/0	0/0	0/0
Hot water boiler, GN	1/300	1/300	1/300	0/0
Steam boiler, EE	0/0	0/0	0/0	0/0
Hot water boiler, EE	0/0	0/0	0/0	1/150
Heat exchanger, VA->AQ	0/0	0/0	0/0	0/0
Heat exchanger, AQ->AR	0/0	0/0	0/0	0/0
Absorption chiller	0/0	0/0	0/0	0/0
Mechanical chiller	1/180	1/180	1/180	1/180
Cooling tower	2/360	2/360	2/360	2/360
Natural gas consumption [MWhyear ⁻¹]	89	89	89	0
Purchase of electricity [MWhyear ⁻¹]	236	236	236	308
Electricity credits [MWhyear ⁻¹]	0	0	0	0
Fixed costs [BRL\$year ⁻¹]	37156	37156	37157	32303
Variable costs [BRL\$year ⁻¹]	125187	127,332	130,103	136048
Total annual cost [BRL\$year ⁻¹]	162334	164448	167259	168351

An increase in 10%, 20%, and 30% in electricity tariffs resulted in the same optimal system with a natural gas hot water boiler, a mechanical refrigeration machine, and two cooling towers to evacuate the waste heat from the refrigeration machine. The results are presented in tab. 9.

Table 9. Optimal economic results considering changes in the price of electricity

	Optimal economic (base)	+10%	+20%	+30%
System composition	Number of equipment/Power installed [kW]			
Gas engine	0/0	0/0	0/0	0/0
Steam boiler, GN	0/0	0/0	0/0	0/0
Hot water boiler, GN	0/0	1/300	1/300	1/300
Steam boiler, EE	0/0	0/0	0/0	0/0
Hot water boiler, EE	1/150	0/0	0/0	0/0
Heat exchanger, VA->AQ	0/0	0/0	0/0	0/0
Heat exchanger, AQ->AR	0/0	0/0	0/0	0/0
Absorption chiller	0/0	0/0	0/0	0/0
Mechanical chiller	1/180	1/180	1/180	1/180
Cooling tower	2/360	2/360	2/360	2/360
Natural gas consumption [MWhyear ⁻¹]	0	89	89	89
Purchase of electricity [MWhyear ⁻¹]	308	236	236	236
Electricity credits [MWhyear ⁻¹]	0	0	0	0
Fixed costs [BRL\$year ⁻¹]	32303	37157	37157	37157
Variable costs [BRL\$year ⁻¹]	136048	144376	153812	164429
Total annual cost [BRL\$year ⁻¹]	168351	181532	190969	201585

When considering that air conditioning habits were extended from 9-12 hours a day (between 19:00 and 7:00) for all representative days of the year, an increase in annual costs and the installation of one less cooling tower were observed, as shown in tab. 10. The refrigeration demand, in this case, increased from 242-355 MWh per year. Table 10 shows that a higher consumption of air conditioning does not lead to a higher thermal load. The same amount of mechanical chillers was sufficient to meet this new habit of residents, although the equipment is used for a longer period of time. Despite the increase in the consumption of chilled water, AF, consuming 12 hours per day, the thermal load was lower than the previous consumption habits, consuming 7 hours per day. This low thermal load implied in less cooling water, AR, reducing the installed power of the cooling tower.

The next sensitivity analysis considered an increase of 10% and 20% in the demands of electricity, heating, and refrigeration, simultaneously, as shown in tab. 11. The rise in energy demands resulted in higher total annual costs on account of more significant variable costs. Interestingly, no additional installed capacity was required, so the optimal economic system configuration did not change. This indicates that the optimal solution is resilient to slight energy demand changes. Energy tariffs did not vary, only the demands, resulting in changes only in the amounts of utilities consumed to satisfy the energy demands.

Table 10. Optimal economic results considering changes in air conditioning habits

	More cooling	Optimal economic (base)
System composition	Number of equipment/power installed [kW]	
Gas engine	0/0	0/0
Steam boiler, GN	0/0	0/0
Hot water boiler, GN	0/0	0/0
Steam boiler, EE	0/0	0/0
Hot water boiler, EE	1/150	1/150
Heat exchanger, VA->AQ	0/0	0/0
Heat exchanger, AQ->AR	0/0	0/0
Absorption chiller	0/0	0/0
Mechanical chiller	1/180	1/180
Cooling tower	1/180	2/360
Natural gas consumption [MWhyear ⁻¹]	0	0
Purchase of electricity [MWhyear ⁻¹]	355	308
Electricity credits [MWhyear ⁻¹]	0	0
Fixed costs [BRL\$year ⁻¹]	31153	32303
Variable costs [BRL\$year ⁻¹]	147993	136048
Total annual cost [BRL\$year ⁻¹]	179147	168351

Table 11. Optimal economic results considering changes in energy demands

	Optimal economic (base)	+10%	+20%
System composition	Number of equipment/Power installed [kW]		
Gas engine	0/0	0/0	0/0
Steam boiler, GN	0/0	0/0	0/0
Hot water boiler, GN	0/0	0/0	0/0
Steam boiler, EE	0/0	0/0	0/0
Hot water boiler, EE	1/150	1/150	1/150
Heat exchanger, VA->AQ	0/0	0/0	0/0
Heat exchanger, AQ->AR	0/0	0/0	0/0
Absorption chiller	0/0	0/0	0/0
Mechanical chiller	1/180	1/180	1/180
Cooling tower	2/360	2/360	2/360
Natural gas consumption [MWhyear ⁻¹]	0	0	0
Purchase of electricity [MWhyear ⁻¹]	308	368	402
Electricity credits [MWhyear ⁻¹]	0	0	0
Fixed costs [BRL\$year ⁻¹]	32303	32303	32303
Variable costs [BRL\$year ⁻¹]	136048	162774	177541
Total annual cost [BRL\$year ⁻¹]	168351	195078	209844

When analyzing the influence of the FAM on the optimal economic results, the initial $FAM = 0.20 \text{ year}^{-1}$ was varied as shown in tab. 12. It is observed that a decrease in FAM causes a reduction in total annual costs, but the configuration remains constant, except for the case where the depreciation factor is 0.10 year^{-1} (equivalent to a long lifetime of the equipment or low interest rate), in which the electric hot water boiler is replaced by the natural gas hot water boiler. The system configuration obtained at this point was the same configuration obtained when increasing the electricity tariff and decreasing the natural gas tariff. When the sensitivity analysis results in a change in the system configuration, the same system appears as the optimal system. This change consists of replacing the hot water boiler, GN, with a hot water boiler, EE.

Table 12. Optimal economic results considering different amortization factors

	$FAM = 0.30$ [year ⁻¹]	$FAM = 0.25$ [year ⁻¹]	$FAM = 0.20$ [year ⁻¹]	$FAM = 0.15$ [year ⁻¹]	$FAM = 0.10$ [year ⁻¹]
System composition	Number of equipment/Power installed [kW]				
Gas engine	0/0	0/0	0/0	0/0	0/0
Steam boiler, GN	0/0	0/0	0/0	0/0	0/0
Hot water boiler, GN	0/0	0/0	0/0	0/0	1/300
Steam boiler, EE	0/0	0/0	0/0	0/0	0/0
Hot water boiler, EE	1/150	1/150	1/150	1/150	0/0
Heat exchanger, VA->AQ	0/0	0/0	0/0	0/0	0/0
Heat exchanger, AQ->AR	0/0	0/0	0/0	0/0	0/0
Absorption chiller	0/0	0/0	0/0	0/0	0/0
Mechanical chiller	1/180	1/180	1/180	1/180	1/180
Cooling tower	2/360	2/360	2/360	2/360	2/360
Natural gas consumption [MWhyear ⁻¹]	0	0	0	0	89
Purchase of electricity [MWhyear ⁻¹]	308	308	308	308	236
Electricity credits [MWhyear ⁻¹]	0	0	0	0	0
Fixed costs [BRL\$year ⁻¹]	48455	40379	32303	24227	18578
Variable costs [BRL\$year ⁻¹]	136047	136,047	136048	136047	133051
Total annual cost [BRL\$year ⁻¹]	184503	176427	168351	160275	151630

For the optimal economic solution, the ratio α between the electricity and natural gas tariffs was $\alpha = 1.37$. The subsequent sensitivity analysis considered that the α value was increased until cogeneration became economically feasible. This took place for $\alpha = 3.15$, equivalent to increasing electricity from 442-1015 BRL/MWh (129% increase) or reducing natural gas from 332-140 BRL/MWh (58% decrease). The results of the optimal economic system for $\alpha = 3.15$ are presented in tab. 13. As can be seen, the installation of the gas engine eliminated the electric hot water boiler and required the installation of the hot water-cooling water heat exchanger. Besides, there is an advantage in using a cogeneration module consuming natural gas for electricity production, obtaining benefits from the exports of surplus electricity into the grid. Table 13 shows the infeasibility of installing the gas engine for cogeneration. Cogeneration is also penalized by the need to install the heat exchanger AQ-AR to evacuate residual heat at $t_0 + 5 \text{ }^\circ\text{C}$.

Table 13. Optimal economic result considering $\alpha = 3.15$

	$\alpha = 3.15$	Optimal economic (base)
System composition	Number of equipment/ power installed [kW]	
Gas engine	1/108	0/0
Steam boiler, GN	0/0	0/0
Hot water boiler, GN	0/0	0/0
Steam boiler, EE	0/0	0/0
Hot water boiler, EE	0/0	1/150
Heat exchanger, VA->AQ	0/0	0/0
Heat exchanger, AQ->AR	1/150	0/0
Absorption chiller	0/0	0/0
Mechanical chiller	1/180	1/180
Cooling tower	2/360	2/360
Natural gas consumption [MWhyear ⁻¹]	241	0
Purchase of electricity [MWhyear ⁻¹]	237	308
Electricity credits [MWhyear ⁻¹]	79	0
Fixed costs [BRL\$year ⁻¹]	66928	32303
Variable costs [BRL\$year ⁻¹]	238384	136048
Total annual cost [BRL\$year ⁻¹]	305312	168351

The electricity-based energy system was not sufficiently robust to withstand drastic variations in energy resources prices (electricity and natural gas) and the amortization factor.

At this point, it is valid to recognize that this study applied a comprehensive, transparent, well-established methodology to establish the optimal energy supply system from an economic viewpoint. The objective of the optimization model was to design an energy system to satisfy the energy demands of a residential building with a minimum total annual installation and operation costs. The optimal solution obtained, which was the same as the proposed reference system, was entirely dependent on the electric grid. Therefore, the results demonstrated that for the scenario considered herein (climatic data, energy demands, operating conditions, electric grid restrictions, energy resources tariffs), electricity purchased from the electric grid was the most economical alternative.

Although cogeneration has been successfully employed worldwide, it was not economically viable in the present case study. Several factors contributed to the system's preference for grid electricity over natural gas and cogeneration: the flat rate electricity tariffs, low and sporadic heating demands of the building, high investment cost of the single-effect absorption chiller relative to the mechanical chiller, and lack of a thermal energy storage unit to decouple energy services production from consumption, thereby allowing for steady operation of the gas engine.

Very different results were obtained in a previous study by Pina *et al.* [28] in which trigeneration was found economically attractive to supply the energy demands of a Brazilian university hospital. Available equipment included renewable energy technologies (photovoltaic panels and solar collectors), thermal energy storage, absorption chiller, mechanical chiller, and

internal combustion gas engine for cogeneration. The results showed that trigeneration was the most advantageous solution. Still, the system took advantage of the electric energy compensation system to export electricity into the grid and reduce electricity purchase costs. What these contrasting results indicate is that there is no unique solution when it comes to energy systems optimization, which must always be evaluated on a case-by-case basis taking into account the circumstances in which the study is performed (energy resources availability and prices, energy products required, technology options available, analysis time frame, investment costs, among others).

Conclusions

The study presented herein optimized an energy system to be installed in a residential building. The optimization procedure focused on the minimization of total annual costs and employed commercially available equipment. Economic and legal aspects took into account Brazilian regulations. The study case was a residential building, with 20 floors and 40 apartments, located in the northeast Brazil. The result of the optimization was very dependent on the purchase of electricity from the grid, which was used to satisfy the electricity demands directly and to operate an electric boiler and a mechanical chiller.

The optimal economic solution obtained was associated with several variables that can change over time. Six sensitivity analyses were carried out by varying the tariffs of natural gas and electricity, energy demands, the habits of residents, the amortization factor, and the ratio between the tariffs of electricity and natural gas. The results of the optimization usually included natural gas for water heating whenever the price of natural gas was reduced, or the price of electricity was increased. The use of natural gas for water heating was part of the optimal solution when the depreciation factor was decreased to 0.1.

The increase in all energy demands by 10% and 20% did not change the optimal system, except for the variable costs that increased as the system consumed more electricity. With the change in the air conditioning habits of the residents, variable costs increased considerably due to the increase in the purchase of electricity. The only point where economic benefits were observed with the use of cogeneration in the sensitivity analysis was when the ratio between the electricity and natural gas tariffs was increased to 3.15, more than doubling the value of the electricity tariff, which could be an extreme result obtained in the case of a crisis in hydroelectric generation.

The implementation of cogeneration, which has proven economic benefits in other case studies, was not verified herein. For the residential sector in a tropical climate, hot water demands are very low, which is challenging when attempting to generate heat and electricity with a cogeneration module simultaneously. The constant electricity tariff applied to the residential sector also favors electricity consumption from the grid. The high capital costs associated with the installation of absorption chillers also favors the installation of mechanical chillers, hindering the installation of trigeneration.

Acknowledgment

The authors thank the National Council for Scientific and Technological Development (CNPq) for the productivity grant 307394/2018-2 and M. Sc. Scholarship. Thanks are extended to the Spanish Government (Energy Program), the Government of Aragon (Ref: T55-17R), and the EU Social Fund (FEDER Program 2014-2020 *Building Europe from Aragon*) for funding to research project ENE2017-87711-R.

Nomenclature

CFI – fixed costs, [\$]
 $C_{INV}(i)$ – individual capital cost
 $COM(d, h, GN)$ – purchase of natural gas in the period (d, h) , [kW]
 $COM(d, h, EE)$ – purchase of electricity in the period (d, h) , [kW]
 $COM(d, h, j)$ – purchase of j in the period (d, h) , [kW]
 $CON(d, h, j)$ – consumption of j in the period (d, h) , [kW]
 CRF – capital recovery factor
 CVA – variable costs, [\$]
 c – specific heat, [$\text{kJkg}^{-1}\text{K}^{-1}$]
 $DEM(d, h, j)$ – demand of j in the period (d, h) , [kW]
 FAM – amortization factor
 FMO – maintenance and operating factor
 iy_r – interest rate, [year^{-1}]
 $K(i, j)$ – production coefficients
 k – conductivity, [$\text{Wm}^{-1}\text{K}^{-1}$]
 ny_r – lifetime of equipment, [year]
 PEE – prices of electricity, [$\text{\$kW}^{-1}\text{h}^{-1}$]
 PGN – prices of natural gas, [$\text{\$kW}^{-1}\text{h}^{-1}$]
 $PIN(i)$ – total installed power of i , [kW]
 $P_{NOM}(i)$ – nominal power of i , [kW]
 $PRO(d, h, i)$ – total production from i in the period (d, h) , [kW]
 $PER(d, h, j)$ – loss of j in the period (d, h) , [kW]
 $TEC(i)$ – number of i technologies installed
 $VEN(d, h, EE)$ – sale of electricity in the period (d, h) , [kW]

$VEN(d, h, j)$ – sale of j in the period (d, h) , [kW]
 $X(i, d, h, j)$ – energy flow of j produced or consumed from i , [kW]
 $YUD(j)$ – indicators of demand
 $YUP(j)$ – indicators of purchase
 $YUS(j)$ – indicators of exports
 $YUW(j)$ – indicators of waste

Acronyms

AA – ambient air
AF – chilled water
AQ – hot water
AR – cooling water
EE – electricity
EEAQ – electric hot water boiler
EEVA – electric steam boiler
FAAQ – single-effect absorption chiller
FMAR – mechanical chiller
GN – natural gas
GNVA – natural gas steam boiler
GNAQ – natural gas hot water boiler
ICAR – cooling tower, to evacuate heat
MGAQ – gas engine + hot water heat recovery unit
MILP – mixed integer linear program
TCAQ – hot water-cooling water heat exchanger
TCVA – steam-hot water heat exchanger
VA – steam

Greek symbols

α – ratio electricity: natural gas tariffs
 ρ – specific mass, [kgm^{-3}]

References

- [1] Lozano, M. A., et al., Operational Strategy and Marginal Costs in Simple Trigeneration Systems (in Portuguese), *Energy*, 34 (2009), 11, pp. 2001-2008
- [2] ***, EPE, Use of Air-Conditioning in the Brazilian Residential Sector: Perspectives and Contributions to Energy Efficiency Advances, 2018
- [3] ***, EPE, Brazilian Energy Balance, 2019. <<http://www.epe.gov.br/sites-pt/publicacoes-dados-abertos/publicacoes/PublicacoesArquivos/publicacao-377/topico-494/BEN%202019%20Completo%20WEB.pdf>>, 2020
- [4] ***, International Energy Agency – IEA, Tracking Buildings: Not on track, 2020a. Available at: <<https://www.iea.org/reports/tracking-buildings/cooling>>, 2020
- [5] Carvalho, M., et al., Life Cycle Analysis as a Decision Criterion for the Implementation of Solar Photo-voltaic Panels in as Northeast Brazil Hospital, *Energy, Transp. Glob. Warm.*, (2016), June, pp. 295-314
- [6] Delgado, D., et al., Photovoltaic Solar Energy in the Economic Optimisation of Energy Supply and Conversion, *IET Renew. Power Gener.*, 12 (2018), 11, pp. 1263-1268
- [7] Carvalho, B., et al., Multicriteria Optimization of Renewable-Based Polygeneration System For Tertiary Sector Buildings, *Environ. Eng. Manag. J.*, 18 (2019) 11, pp. 2441-2453
- [8] Brahman, F., et al., Optimal Electrical and Thermal Energy Management of a Residential Energy Hub, *Integrating Demand Response and Energy Storage System Energy Build.*, 90 (2015), Mar., pp. 65-75
- [9] Esther, B. P., Kumar, K. S., A Survey on Residential Demand Side Management Architecture, Approaches, Optimization Models and Methods, *Renewable and Sustainable Energy Reviews*, 59 (2016), June, pp. 342-351

- [10] Lauinger, D., *et al.*, A Linear Programming Approach to the Optimization of Residential Energy Systems, *Journal Energy Storage*, 7 (2016), Aug., pp. 24-37
- [11] Iturriaga, E., *et al.*, A General Model for the Optimization of Energy Supply Systems of Buildings, *Energy*, 138 (2017), Nov., pp. 954-966
- [12] Szypowski, M., *et al.*, Optimization of Energy-Supply Structure in Residential Premises Using Mixed-Integer Linear Programming, *IEEE Trans. Ind. Electron.*, 66 (2019), 2, pp. 1368-1378
- [13] Abbasi, M. H., *et al.*, A Methodology to Obtain the Foremost Type and Optimal Size of the Prime Mover of a CCHP System for a Large-Scale Residential Application, *Appl. Therm. Eng.*, 135 (2018), May, pp. 389-405
- [14] Zheng, X., *et al.*, A MINLP Multi-Objective Optimization Model for Operational Planning of a Case Study CCHP System in Urban China, *Appl. Energy*, 210 (2018), Jan., pp. 1126-1140
- [15] ***, U. S. Department of Energy; Building Technologies Office, 2017. EnergyPlus. Version 8.7.0. <<https://energyplus.net/>>, 2020
- [16] ***, Lingo Systems. 2017. Lingo. Version 16.0. <<http://www.lindo.com/index.php/products/lingo-and-optimization-modelling>>, 2020
- [17] Roriz, M. 2012. Climate archives of Brazilian Municipalities, Available at: <http://www.roriz.eng.br/epw_9.html>, 2020
- [18] ***, ABNT, NBR. 15220-2: Desempenho Técnico das Edificações - Parte 2," 2005. Parte 2, v. 2.
- [19] Yeomans, H. Grossmann, I. E., A Systematic Modelling Framework of Superstructure Optimization in Process Synthesis, *Comput. Chem. Eng.*, 23 (1999), 6, pp. 709-731
- [20] ***, Brazilian Electricity Regulatory Agency, 2010, Resolution No. 414, of September 9, 2010, Establishes the general conditions for the supply of electricity in a updated and consolidated manner. <<http://www2.aneel.gov.br/cedoc/ren2010414comp.pdf>>, 2016
- [21] ***, Energisa, Conventional Low Voltage Rate Modality, 2017, <https://www.energisa.com.br/Paginas/informacoes/taxas-prazos-e-normas/tipos-tarifas.aspx>, 2020
- [22] ***, PBGAS, "Tarifas – Companhia Paraibana de Gás," 2017. <http://www.pbgas.com.br/?page_id=1477>, 2020
- [23] ***, Brazilian Electricity Regulatory Agency, Resolution no 482, of April 17, (2012), Establishes the general conditions for access of distributed micro and mini-generation and creates an electricity compensation system, 2012
- [24] ***, Brazilian Electricity Regulatory Agency, Resolution no 687, of November 24, (2015), Alter resolution no 482, 2015
- [25] Carvalho, M., *et al.*, Synthesis of Trigeneration Systems: Sensitivity Analyses and Resilience, *Sci. World J.*, 2013 (2013), ID604852
- [26] Yoshida, S., *et al.*, Sensitivity Analysis in Structure Optimization of Energy Supply Systems for a Hospital, *Energy Convers. Manag.*, 48 (2007), 11, pp. 2836-2843
- [27] Ren, H., Gao, W., A MILP Model for Integrated Plan and Evaluation of Distributed Energy Systems, *Appl. Energy*, 87 (2010), 3, pp. 1001-1014
- [28] Pina, E. A., *et al.*, Tackling Thermal Integration in the Synthesis of Polygeneration Systems for Buildings, *Applied Energy*, 269 (2020), 115115