

## INVESTIGATION OF THE THERMAL BEHAVIOR AND ENERGY CONSUMPTION OF REFRIGERATION SYSTEMS

by

**Miklos KASSAI\***

Department of Building Service Engineering and Process Engineering,  
Budapest University of Technology and Economics,  
Budapest, Hungary

Original scientific paper  
<https://doi.org/10.2298/TSCI190213170K>

*The object of this research study is to develop a thermal simulation model that can be used to investigate the thermal parameters of the refrigerant systems (with ON/OFF and PID control) used in cooling chambers. Moreover, the model was further developed which takes into account also the types of compressors, feeder, and control units used commonly in practice for energetic investigations. Using the measured energy consumption data obtained by experimental tests during the previous phase of this research work, the validation of the developed energy simulation model by MATLAB R2016a could be also achieved with good agreement. The MATLAB software seemed to be the most appropriate tool for numerical investigations on the energy consumption of refrigeration systems used in commercial cold stores and transient behavior of the indoor air temperature of the cold store, cooling energy performance and consumed energy to the goods stored in cold store.*

Key words: *commercial refrigeration, cold store, ON/OFF control, PID control, energy consumption, simulation model*

### Introduction

Refrigeration is a process of moving heat from one space to another under controlled conditions. A refrigerator provides heat transfer from lower temperature region to higher temperature region. The main components of a refrigeration cycle are compressor, condenser, expansion valve, and evaporator. Reduction in the energy consumption of refrigeration systems is crucial topic of the industry. The energy consumption is significant influenced by the type of the compressor, the control techniques of compressor, expansion valve and refrigerant [1-3]. The most existing operating commercial and domestic air-to-air refrigeration systems worldwide are mostly still based on traditional ON/OFF controller systems resulting high energy consumption, poor temperature control and limited operational conditions [4, 5]. It is a simple controller where the output from the device is either on or off. It is a type of control action in which the manipulated variable is changed to a maximum or minimum value. When the temperature is above the setting in the thermostat a switch is closed which turn on the compressor and air blowing fan causing air inside to cool down. When the temperature gets to the thermostat's setting, the switch is opened shutting off the compressor. Basically, the on-off controller in the refrigerator compares the real inner temperature with the desired temperature and feeds

---

\* Author's, e-mail: [kas.miklos@gmail.com](mailto:kas.miklos@gmail.com)

this error signal to the control input of the switch block of the controller. A proportional-integral-derivative (PID) controller is more appropriate to control the inner temperature of the refrigerator and thus gives the best performance for the response opposed to ON/OFF controller. The controller takes a measured value from a process or other apparatus and compares it with a reference set point value. The difference is then used to adjust some input to the process in order to bring the process measured value back to its desired set point [6]. The PID controller makes rapid and precise control possible [7-11]. This is also true in reality, provided that the system is correctly defined, taking disturbances into consideration accurately. These are the conditions for the proper definition of constants based on the use of the appliance. If these are realized, a properly operating system is established, which is capable of correcting the error on the basis of its past development and its predictable degree. This is why PID control is widely spread these days, while in the case of building engineering only proportional-integral control is applied [12-17]. In the close future, the use of developed controlled compressors will be also mandatory in industrial refrigeration technologies, as it happened in the case of air-conditioners in year 2013 by introduction of the ErP-Directive in the territory of the EU. This stipulates, that all air-conditioners with a cooling capacity lower, than 11 kW must apply inverter control, and 125 W power fans (a component of the appliance) need to be certified. Addressing this regulation, the producer of Sinclair has developed the already described, universal control unit, with the application of which their own refrigerator generators became controllable in terms of speed of rotation, but their product has been not tested in real cold store under real environmental operation conditions before and their PID controller is untuned. The energetic comparison investigation is conducted in this research study by the fact, that cold stores operated by minor enterprises, primary producer have become more and more popular in Hungary, primarily used for some type of food industrial (meats like sausage, fruits, and vegetables) storage purposes. With government support these minor enterprises are also given the opportunity to purchase the cooling technology for up-to-date, low-consumption, high advanced cold stores. This could not only result in energy savings, but through the solution described in the automatic control section, a more stable air temperature of the chamber, consequently, a more stable conservation (preservation) of the consistence of goods stored within could be achieved. In a previous research project, the energy consumption of a newly developed DC inverter refrigerator (used more and more frequently in the commercial sector) was optimized, which included a speed-controlled compressor, an electronic expansion valve and the PID controller. In order to achieve the research goals, an experimental measuring station was built in the showroom of the domestic market leader company selling refrigeration systems. The main part of the measuring system was a cooling chamber that contained two identical evaporators: one was powered by the DC-inverter refrigerator, and the other was supplied with refrigeration energy by a cooling unit widely used in the domestic market, which is operated by a conventional piston compressor, a mechanical expansion valve and an ON/OFF (two-position) control technology. Due to the incomplete data supplied by the manufacturer, the PID controller of the DC cooling unit had to be optimized by setting the appropriate proportional, integral and derivative tags to ensure energy-efficient operation. Based on the experimental test data, the combined effects of electronic expansion valve, scroll compressor operation and the correct experimental settings of PID controller in DC refrigerator results around 62,4% energy saving opposed to the traditional ON/OFF controlled appliance under the same operational conditions in the same cold store. The measured daily energy consumption was 14,65 kWh of the traditional ON/OFF system and 5,5 kWh of the PID controlled system [18].

As a continuation of the research, the object is to develop a thermal simulation model that can be used to investigate the thermal parameters of the refrigerant systems (with ON/OFF and PID control) used in cooling chambers. Moreover, the model was further developed which takes into account also the types of compressors, feeder and control units used commonly in practice for energetic investigations. Further object is to validate the developed simulation model with measured data by experimental tests obtained during the previous phase of the research work [18, 19].

### **Development of the thermal simulation model**

As the results obtained from the developed simulation model approximate the experimental results [14, 15] with adequate accuracy, then by changing the characteristic parameters of the system, further conclusions can be drawn regarding its operation and avoid the installation of a new experimental measuring unit or the reconstruction of the existing one, which would require high investment costs. The current stage of the research first comprised the simulation of the effect of the various control systems (PID and ON/OFF) on the energy consumption of the cooling unit. The SIMULINK with MATLAB software was used to develop the simulation models in this research, because it is flexible graphically based software environment used to simulate the thermal behavior of transient systems and offers also control tutorials. Since at this stage of the research work the aim is to compare the ON/OFF and PID controlled systems, only the control method will differ between the simulation models presented later. During the refrigeration, the control system compares the setpoint (the set temperature to be maintained) with the actual air temperature measured in the chamber and controls the refrigeration power accordingly. So-called SimScape elements can be used in the MATLAB SIMULINK module, including thermal elements which are perfectly suitable for the energetic modeling of the refrigeration systems examined in the research project. The characteristic values of each item used had to be specified, *e. g.* the mass and heat capacity of the material (air) in the chamber, evaporator heat transfer coefficient, *etc.* For the development of the simulation model, the technical data (heat transfer surface, heat transfer coefficient) of the evaporator and the chamber were taken into account with values provided by the manufacturer, and the calculations, similarly to the experiments, include a 500 W of internal heat load (*extra heat load*). A thermal model was created during the development of the simulation model; it does not comprise mechanical elements, that is, the refrigeration cycle is not modeled, but it is among the future goals as a continuation of the research.

#### *The developed simulation model for the cooling unit with ON/OFF control*

The mentioned SIMULINK module was used for comparison. Figure 1 shows the structure of the simulation model for the refrigeration systems with ON/OFF control.

#### *The developed simulation model for the cooling unit with PID control*

Figure 2 shows the structure of the simulation model for the refrigeration systems with PID control.

### **Validation of the simulation model by the experimental data**

The PID settings has to be identical to ensure that the simulation results are comparable to the measured values obtained during the experiments. Accordingly, the mentioned

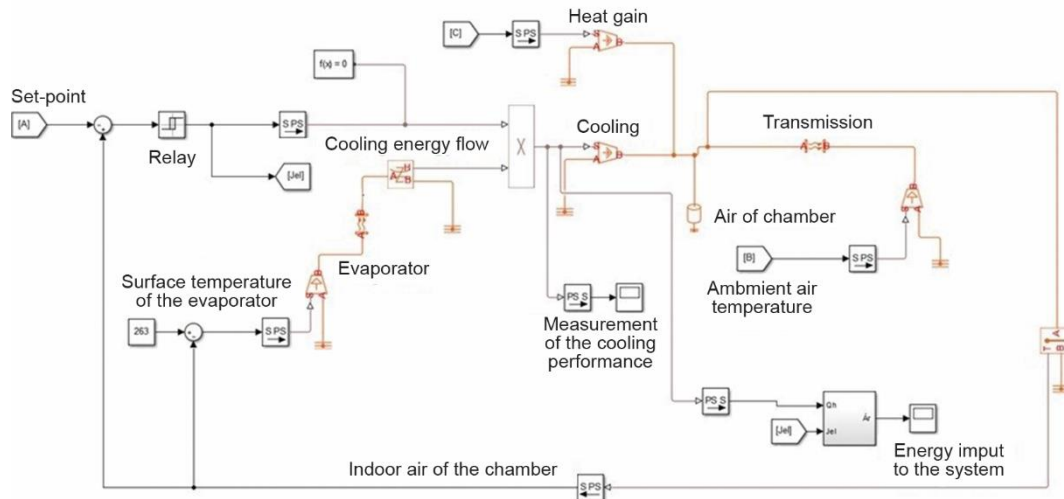

Figure 1. The connection diagram of simulation model for the system with ON/OFF control

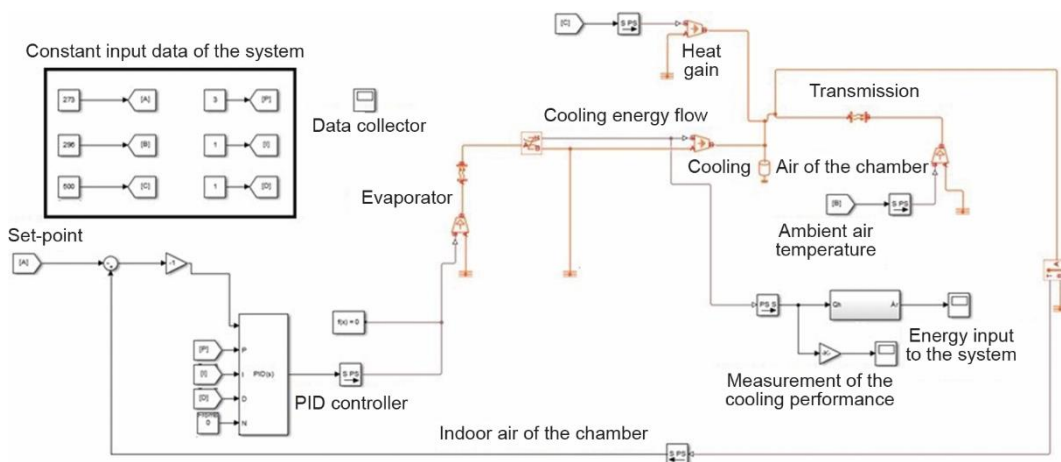
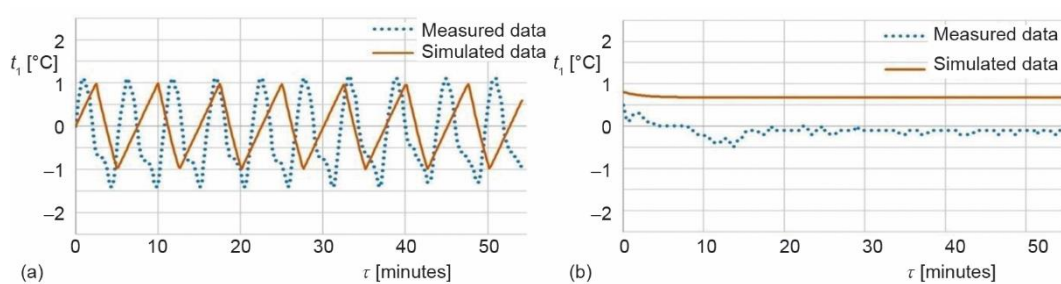

Figure 2. The connection diagram of simulation model for the system with PID control

overdamped system was compared with the third measurement sequence [1] (in a non-transient state). Figure 3 shows the system with PID control and with ON/OFF control.

The difference between the simulation model and the measured values can also be attributed to the physical characteristics and limits of the equipment used for the measurements. For example, the thermometer also has a measuring uncertainty, and it is not mounted onto the evaporator due to the mentioned overcooling. In addition, the thermometer can also have a certain inertia which is a parameter dependent on the model of the thermometer. However, ideal technical parameters were assumed for the definition of all elements during the development of the simulation model.



**Figure 3. Comparison of the simulated and measured indoor air temperature fluctuation in the chamber for the unit with ON/OFF control (a) and PID control (b)**

The difference between the measured and simulated results was maximum 1.1 °C that can be seen in fig. 3. The reason of the differences can be the following:

- the thermal simulation model does not contain the other elements of the refrigeration circuit (compressor, condenser, expansion valve, and pipelines),
- the PID directly controls the evaporator due to the omission of the refrigeration cycle,
- the location, resolution and measurement uncertainty of the measuring devices can also cause deviation from the ideal values of the simulation, and
- for the model, the nominal values provided by the manufacturer were used, which can be different from reality.

To show good agreement between the test and numerical results further development on the simulation model is important.

### Extension of the simulation model by detail modeling of the refrigeration cycle

Findings of research works performed in the past in the area show that the results of the simulation method can be further refined by considering the refrigerant. To do this, the whole refrigeration cycle must be modeled since the refrigerant circulates through this. From our point of view the useful phenomenon is the heat drain from the chamber, and it is a result of this cycle. The MATLAB SIMULINK module makes it possible to model this as well because it includes a toolkit for biphasic systems. Since the refrigerant in the system is either gas or liquid, it can be treated as a biphasic substance. The model thus constructed can be seen in fig. 4.

Figure 4 shows that the model has become significantly more complex compared to the previously developed thermal model. The blue parts are elements of the biphasic material and the red units are the thermal elements (an improved version of the previous model):

- *Controllable mass flow*: this is essentially the compressor, which provides the mass flow and pressure increase corresponding to the control.
- *Pipelines with heat loss*: for example, the condenser and the evaporator. Depending on the geometry of the pipe and the material passing through it, the model calculates the amount of heat the pipe section can dissipate.
- *Throttle*: equivalent of the expansion valve. The extent of the throttle can be adjusted, and
- *Biphasic substance properties*: this element makes it possible to connect the biphasic substance to the model by defining it.

The major disadvantage of the model is that a lot of data must be provided which were not necessary to specify in the cases that have been investigated so far; all of them is related to the refrigeration cycle. These data are summarized in tab. 1.

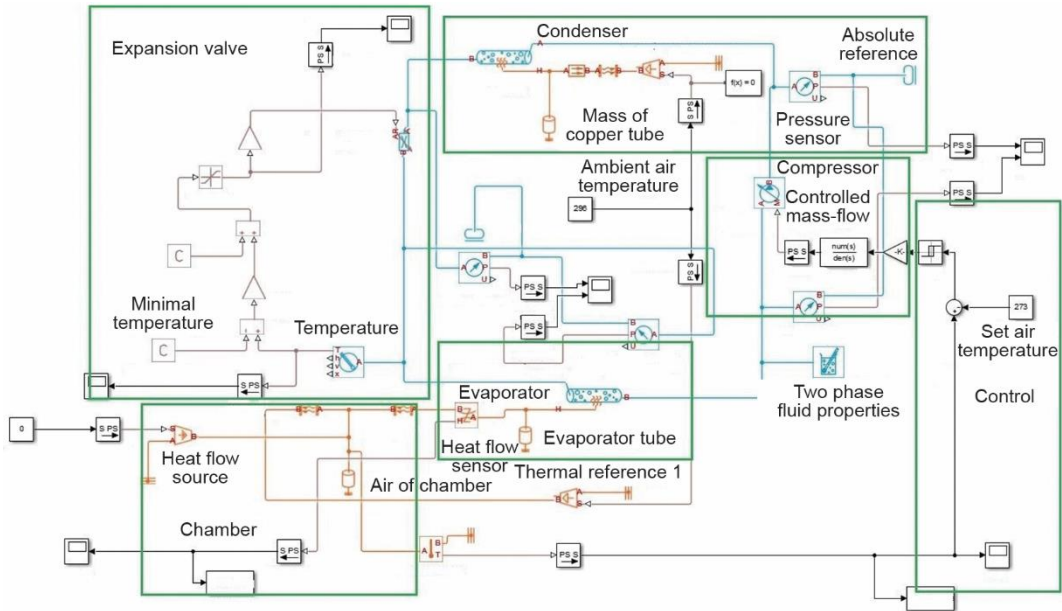

Figure 4. Schematic diagram of the extended simulation model for refrigeration cycle

Table 1. Parameters taken into consideration for the refrigeration cycle model

Part	Required data	Part	Required data	
Condenser and evaporator	Pipe length	Biphasic substance	Pressure vector	
	Diameter		Minimum specific internal energy	
	Cross section		Maximum specific internal energy	
	Density		For liquid: Normalized internal energy vector and as its function the:	
	Specific heat of its material		specific volume	
	Density of its material		specific entropy	
	Resistance		temperature	
	Gas proportion of the medium passing through		kinematic viscosity	
	Initial pressure of the medium passing through		thermal conductivity	
Expansion valve	Minimum cross section		Prandtl number	
	Maximum cross section		Internal energy vector of saturated liquid	
	Minimum temperature		The above for gaseous state	
	Maximum temperature			
Compressor	Transferred mass flow			

The number of data required for the biphasic substance is high. In order to obtain a realistic behavior for the liquid in the 0-3 bar pressure range, the pressure has to be divided into 60 parts. Each such part has 25 values per quantity. This means that the number of ordered pieces of data for a phase is 10500. Therefore, 21000 pieces of data are needed to define the entire biphasic substance, and the data in tab. 1 are needed in addition for the operation of the system. The additional unknown parameters were determined by estimation. Figures 5 and 6 show the progression of the chamber temperature and refrigeration power for the ON/OFF controlled case.

We can see that the refrigeration power shown in fig. 6 does not reach 0 W, not even during compressor downtime. This refrigeration power comes from the refrigerant which is warming up constantly during compressor downtime, and thus it drains heat from the chamber. Using the extended simulation model developed, also the system pressure, internal energy, vapor content or specific volume can be measured at any point of the system.

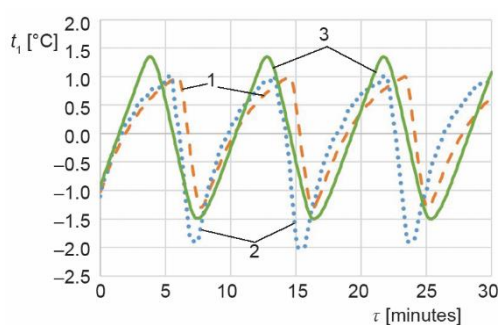

**Figure 5.** The change of chamber indoor air temperature over time based on measured, corrected simulation and extended simulation calculations in case of refrigeration systems with ON/OFF control; 1 – corrected simulation values, 2 – measured data, 3 – extended simulation values

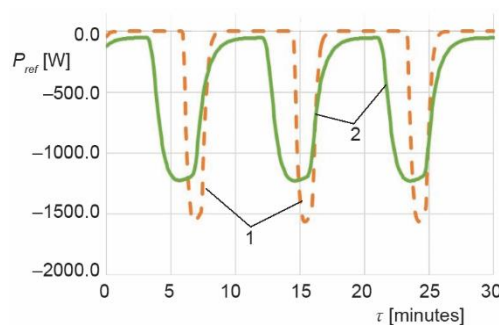

**Figure 6.** The change of cooling power over time in case of the corrected and the extended simulation; 1 – corrected simulation values, 2 – extended simulation values

### Transient investigations performed by simulation

By way of simulation, during the research, the effect the fresh goods stored in the chamber have on the air temperature of the chamber, the cooling power and the energy consumption could be also investigated. The 5 kg goods near the specific heat of water with an initial temperature of 27 °C were placed in the chamber. First, it was necessary to determine the heat transfer coefficient between the product and the chamber air. Based on the convection operation of the evaporator fan, it is specified as 15 W/m<sup>2</sup>K. The test is carried out in a non-transient state, and the product appears in the chamber in the 40<sup>th</sup> minute. Figure 7 shows the SIMULINK mathematical representation used for this. A shortcoming of the model that the goods are placed instantly, so the door opening is not yet modeled; this is among the goals during the future continuation of the project. Although each and every component has to be modelled by the model developer in MATLAB, which makes the parameter specification slightly cumbersome, the SIMULINK PID Controller block (P, PI, or PID) provides a significant development environment to model an ON/OFF and PID controlled refrigerators well. For this reason MATLAB software proves the most appropriate tool for numerical investigation on

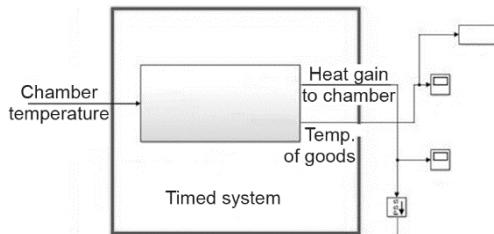

**Figure 7.** Connection diagram of the timed system model

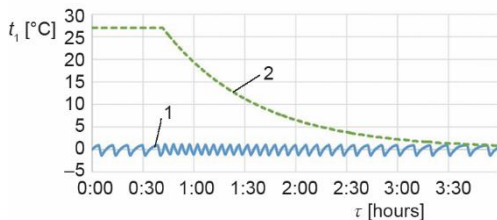
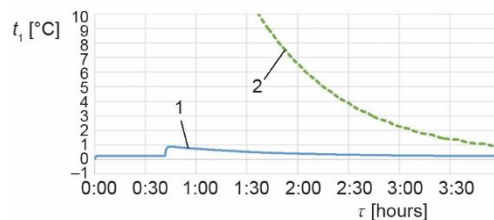

**Figure 8.** The temperature fluctuation of air in ON/OFF controlled chamber and the goods over time; 1 – chamber temperature, 2 – goods temperature

the energy consumption of air-conditioning systems used in commercial cold stores and transient behavior of the indoor air temperature of the cold store, cooling energy performance and consumed energy to the goods stored in cold store.

The results are summarized in figs. 8-12. Figure 8 shows the temperature fluctuation of air in ON/OFF controlled chamber and the goods over time.

Figure 9 shows the temperature fluctuation of air in PID controlled chamber and the goods over time.



**Figure 9.** The temperature fluctuation of air in PID controlled chamber and the goods over time; 1 – chamber temperature, 2 – goods temperature

Figure 10 shows the cooling power fluctuation in the ON/OFF controlled chamber over time after placement of the goods.

Figure 11 shows the change in the refrigeration power in the PID controlled systems over time.

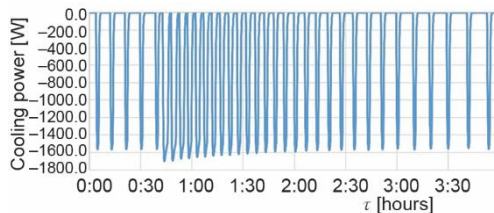

**Figure 10.** The cooling power fluctuation in the ON/OFF controlled chamber over time after placement of the goods

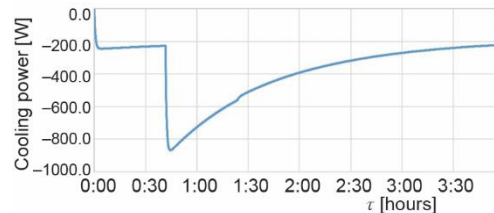

**Figure 11.** The cooling power fluctuation in the PID controlled chamber over time after placement of the goods

Figure 12 shows the energy consumption changing of the PID and ON/OFF controlled refrigeration systems over time following the placement of the goods.

The diagrams clearly show the effect of the placed product. In the ON/OFF case, the product can quickly heat up the air due to the high temperature difference present between the product and the chamber air when the goods are placed. Since the cooling unit performs the control based on the temperature of the chamber air, it is deactivated at a temperature of  $-1\text{ }^{\circ}\text{C}$



just the same, and it can cool this almost in the same way as before. This increases the number of the switching operations which can damage the compressor, and thus shorten its life span. In addition, the effect of the starting current occurs more frequently, resulting in a difference compared to the energy consumption of the PID controlled refrigeration system, shown in fig. 12. This points out that the difference between the two control methods becomes more significant with the increase of the goods placement frequency. In the PID controlled scenario, the conclusion is that the system can flexibly follow the refrigeration demand of the placed product and is able to provide the required refrigeration power efficiently if the control is set up properly. After the product has been cooled appropriately, only the transmission heat loss has to be covered by the machine; that is, it only has to ensure the maintenance of the temperature.

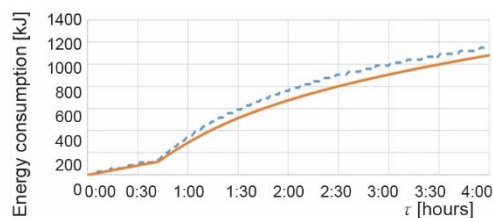

**Figure 12. The energy consumption changing of the PID and ON/OFF controlled refrigeration systems over time following the placement of the goods**

## Conclusions

Based on the national and international research studies and regulations it is particularly significant to develop simulation models to enable the energetic investigation of air-conditioning systems in more detail and more realistically than with the recent methods provide in the current engineering practice. My aim was to improve the energy conscious refrigeration system designing, and develop the current calculation procedures and completing design data. To achieve this, object of this research was to work out simulation procedure to determine the energy consumption of refrigeration systems used in commercial sectors with more detail method and more realistically results than provided the recent standards and regulations. By this way the aim of the recent research work was to support also the building service engineers and designers to make more exact energy certifications for buildings. In this study the investigation of thermal and energetic properties of PID and ON/OFF controlled refrigeration systems was conducted considering also the transient effect of the placed product. Using the measured energy consumption data obtained by experimental tests during the previous phase of this research work, the validation of the developed energy simulation model by MATLAB R2016a could be also achieved with good agreement. The result of the transient investigation of 5 kg goods, placed in the chamber, showed that it takes almost four hours to cool down the goods from the initial temperature of 27 °C to around 1 °C and the energy consumption is 17.996 kWh with PID and 19.068 kWh with ON/OFF controlled refrigeration systems. Investigating the energy and as well as the economic impacts of the two systems under transient conditions, the cooling of 5 kg goods in four hours resulted 1.072 kWh (5,62%) energy saving and 0.08672 € saving, considering the national industrial consumer energy price (0.0809 €/kWh), with the PID controlled system compared to the ON/OFF controlled system. The developed simulation model enables the investigation of the thermal behaviors and energy consumption of a designed cold store for building service engineers. Using the model the effect of the control system on the energy consumption and on the cooling rate can be also investigated which can influence also the quality of the stored goods. The developed simulation model is suitable to investigate the energy consumption and thermal behaviors only the refrigeration systems that are operated with ON/OFF or PID controller device.

## Acknowledgment

This research project was financially supported by the National Research, Development and Innovation Office from NRDI Fund [grant number: NKFIH PD\_18 127907], the Janos Bolyai Research Scholarship of the Hungarian Academy of Sciences, and the UNKP-18-4 New National Excellence Program of the Ministry of Human Capacities, Budapest, Hungary. Moreover, the research reported in this paper was supported by the Higher Education Excellence Program of the Ministry of Human Capacities in the frame of Biotechnology research area of Budapest University of Technology and Economics (BME FIKP-BIO).

## Nomenclature

$P$  – power [W]

$t$  – temperature [°C]

Greek symbol

$\tau$  – time [minute]; [hour]

Subscripts

i – indoor air

ref – cooling

## References

- [1] Nyers, J., *et al.*, Investment-Savings Method for Energy-Economic Optimization of External Wall Thermal Insulation Thickness, *Energy and Buildings*, 86 (2014), Jan., pp. 268-274
- [2] Jankovich, D., Osman, K., The Feasibility Analysis of Replacing the Standard Ammonia Refrigeration Device with the Cascade NH<sub>3</sub>/CO<sub>2</sub> Refrigeration Device in Food Industry, *Thermal Science*, 19 (2015), 5, pp. 1821-1833
- [3] Parker, J., *et al.*, Accounting for Refrigeration Heat Exchange in Energy Performance Simulations of Large Food Retail Buildings, *Building Services Engineering Research & Technology*, 38 (2017), 2, pp. 253-268
- [4] Ekren, O., *et al.*, Comparison of Different Controllers for Variable Speed Compressor and Electronic Expansion Valve, *International Journal of Refrigeration*, 33 (2010), 6, pp. 1161-1168
- [5] Hill, F., *et al.*, Influence of Display Cabinet Cooling on Performance of Supermarket Buildings, *Building Services Engineering Research & Technology*, 35 (2013), 2, pp. 170-181
- [6] Ghazanfari, S. A., Wahid, M. A., Heat Transfer Enhancement and Pressure Drop for Fin-and-Tube Compact Heat Exchangers with Delta Winglet-Type Vortex Generators, *Facta Universitatis, Series: Mechanical Engineering*, 16 (2018), 2, pp. 233-247
- [7] Javadi, H., *et al.*, A Comprehensive Review of Backfill Materials and Their Effects on Ground Heat Exchanger Performance, *Sustainability*, 10 (2018), 12, pp. 1-22
- [8] Buonomano, A., *et al.*, A Dynamic Model of an Innovative High-Temperature Solar Heating and Cooling System, *Thermal Science*, 20 (2015), 4, pp. 1121-1133
- [9] Turanjanin, V. M., *et al.*, Different Heating Systems for Single Family House: Energy and Economic Analysis, *Thermal Science*, 20 (2016), Suppl. 1, pp. S309-S320
- [10] Matysko, R., Theoretical Model of the Operation Parameters Regulated by the MIMO and SISO System in a Cooling Chamber, *International Journal of Refrigeration*, 58 (2015), Oct., pp. 53-57
- [11] Ekren, O., *et al.*, Performance Evaluation of a Variable Speed DC Compressor, *International Journal of Refrigeration*, 36 (2013), 3, pp. 745-757
- [12] Buzelin, L. O. S., *et al.*, Experimental Development of an Intelligent Refrigeration System, *International Journal of Refrigeration*, 28 (2005), 2, pp. 165-175
- [13] Hamid, N. H. A., *et al.*, Application of PID Controller in Controlling Refrigerator Temperature, *Proceedings, 5<sup>th</sup> International Colloquium on Signal Processing & Its Applications (CSPA)*, Kuala Lumpur, Malaysia, 2009, pp. 378-384
- [14] Astrom, K. J., Hagglund, T., *PID Controllers: Theory, Design, and Tuning*, 2<sup>nd</sup> ed., Instrument Society of America, Research Triangle Park, N.C., USA, 1995
- [15] Legweel, K. M. B., *et al.*, The Performance of PIP Cascade Controller in HVAC System, *Thermal Science*, 18 (2014), Suppl. 1, pp. S213-S220
- [16] Ogata, K., *Modern Control Engineering*, 4<sup>th</sup> ed. Aeeizh, New Jersey, N. J., USA, 2002

- [17] Raut, K. H., Vaishnav, S. R., A Study on Performance of Different PID Tuning Techniques, *Proceedings, International Conference on Electrical Engineering and Computer Science*, Trivandrum, India, 2012, pp. 250-254
- [18] Kassai, M., *et al.*, Experimental Optimization of Energy Consumption for DC Refrigerator by PID Controller Tuning and Comparison with On-Off Refrigerator, *Thermal Science*, 23, (2019), 2B, pp. 941-952
- [19] Simon, R., Investigation the Energy Consumption of Refrigerating Chamber with Newly Developed DC Inverter Compressor Controller, *Proceedings, Conference of Scientific Students' Associations*, Budapest University of Technology and Economics, Budapest, Hungary, 2016