

APPLICATION OF STOCHASTIC MODELS FOR MINE PLANNING AND COAL QUALITY CONTROL

by

**Dejan R. STEVANOVIĆ^{*}, Božo M. KOLONJA, Ranka M. STANKOVIĆ,
Dinko N. KNEŽEVIĆ, and Mirjana V. BANKOVIĆ**

Faculty of Mining and Geology, University of Belgrade, Belgrade, Serbia

Original scientific paper
DOI: 10.2298/TSCI130201031S

The power plant owner is interested to know in advance the quality of coal to be burnt which should meet maximal efficiency of power plant and the environmental regulations. There is the need to control and to predict the quality of coal at the mine site to meet sulfur emission requirements. Coal quality control between the mine site and the utility plant is a complex problem owing to the variable nature of coal properties (heating value, sulfur, ash), even within the same coal seam. Due to the fluctuation of the coal quality, mine planning and coal homogenization are in fact an optimization problem under uncertain conditions. To deal with these issues a stochastic optimization model is developed for an illustrative coal homogenization problem. Mining block grades from an optimized mining schedule are used to simulate any given homogenization process in stockpiles throughout the mine's life. Sulfur content is treated as lognormally distributed random variable. The objectives of the model include minimizing the expected sulfur content and standard deviation in sulfur content. The methodology was illustrated using the case study on Kolubara surface coal mine.

Key words: *stochastic modelling, mine planning, homogenization, coal quality control, sulfur content*

Introduction

According to the International Energy Agency [1] forecast for the next decades, coal will retain its important role in power generation in Europe and worldwide. The availability of the worldwide coal resources and their price stability are the main reasons for this trend. Coal is the most important fuel in the generation of electricity, accounting for 65% of the power produced in Serbia [2]. In the past, because of the regulated business environment in which utilities operated, coal was viewed as a necessary evil and was always treated as a “pass through” cost. Although the quality of coal impacts boiler operations and subsequent power produced and emissions, utilities had no economic interest in monitoring or managing coal quality.

It is preferred that feeds the plants coals whose properties, especially that of calorific value, conform to the power plant design and whose sulfur content meets the sulfur emission requirement after combustion. It is generally difficult to obtain coal of desired qualities from one

^{*} Corresponding author; e-mail: dstevanovic@rgf.bg.ac.rs

source because of the variable nature of coal properties. Homogenization of coals from different working benches within the single mine or even more mines are therefore becoming mandatory not only from an economic standpoint but also from the necessity of meeting emission requirements.

At the surface mine, coal is extracted from various active working benches and then transported directly to the power plants or to stockyards. Because coal properties can vary considerably, the quality of run of mine (ROM) coal composite will depend on both the quality and quantity of coal mined from each active bench. If it is desired to control the ROM coal quality, the rate of coal production from each active bucket wheel excavator (BWE) should be regulated. The effect of this approach is to blend the coal through the sequence of mining. Such an approach requires a prior knowledge of the coal quality of planned mining blocks.

Coal homogenization is one of mostly used options for optimisation of sulfur emissions from desulfurization power plants [2]. However, decisions about coal homogenization must deal with uncertainty and variability in coal properties, and with the effect of off-design coal characteristics on power plant performance and cost. According to Shih and Frey [3] sulfur and ash content and heating value are considered as normally distributed random variables. The objectives of a model to optimize operation of a plant must include minimizing: (1) the expected (mean) costs of coal blending and (2) the variance of coal blending costs. The cost objective function includes coal purchasing cost, ash disposal cost, sulfur removal cost, and fuel switching costs. Chance constraints include several risk measures, such as the probability of exceeding the sulfur emission standard.

Homogenization piles are frequently used in order to reduce variability and ensure coal stock. In this context, the most important factors, in respect to pile building can be cited as the type of layer disposition, number of layers and added mass. The last variable can significantly reduce pile variability when a large material amount is homogenized, and variability among the lots decreases [4, 5]. The deposition sequence of the material also is able to affect grade predictability of each pile, requiring a more careful mining advance forecast. Often, this scheduling is represented by a vector of grades to coal blocks that will be mined along a given activity time, and geostatistical techniques are used to predict them.

Some previous studies involving blending and homogenization piles and geostatistical simulations are described [6, 7]. US power stations have experienced reduction in SO_x emissions, by up to 20%, by homogenizing coal feeds to power plants [8].

Kriging technique is a very good estimator, but it is not adequate to predict the uncertainty of a process. According to [9], on contrary to kriging, geostatistical simulation methods aim to reproduce in situ variability, and the spatial continuity of the input data set. Models used in this way, aim to replicate the spatial structure of a data set as a whole rather than provide reliable local estimates of an attribute at particular locations.

The stochastic simulated model honors values at the sampled points and it reproduces the same dispersion characteristics of the original data set (*i. e.* the mean, variance and covariance or variogram). It is possible to address questions referring to the dispersion of the grades during operational mine planning or stocking process, since the dispersion characteristics of the original data are maintained.

Coal quality control at the mine planning phase

Mine planning is based on reliable estimates of coal grades of future mining blocks. Consequently, in order to develop any coal quality control strategy, the mine should have the ca-

pability to predict both the quality and the variability of the pertinent coal parameters with some degree of certainty. Coal quality cannot be controlled without some information about possible qualities of future mining blocks. The control of coal quality at the mine phase is usually planned from in-situ coal parameters which are estimated from coal samples. These samples are commonly used to generate maps of in-situ coal parameters. With such maps, it is possible to know in advance the effect of mining from different benches of the surface mine, *i. e.*, whether or not the required quantity and quality of coal can be met during the planning period. Mine planning is divided into four categories: long-term, medium-term, short-term, and operational planning [10].

The primary objective of long-term mine planning is to develop mining sequences which will define the economic limit of the mine. The medium-term planning is concerned with a time span from one to about ten years. It provides information necessary for forecasting future production and cost. There is practical limitation in controlling coal quality during the long and medium-term planning, owing to limited information about grades. The short-term planning contains all activities which are planned between one and twelve months period. The short range plan defines resources and labor requirements, future production and cost. More distinct information about the nature of mineralization and equipment performance is required in short range than medium range planning.

Operational planning is concerned with daily or weekly requirements of the mine. Proper operational planning must conform to short term mine plans as well as satisfying many practical details that are unique to day to day operations. Grade control problems are usually incorporated in the operational planning provided that the necessary detail information is known in advance. The most common planning objective is maximization of tonnage, while meeting the requirements of physical and geological constraints, policies and mining methods. The basic data required in any operational planning are coal quality and capacity. Difficulties in optimum production schedule are caused by variability of grade and inability to accurately predict grades of smaller mining units. Therefore, detailed information on coal properties is essential for reliable operational mine planning [8].

Generally two types of grade variability exist in the coal chemical composition (fig. 1):

- long-term variability as measured by trends of monthly or longer duration, and
- operational variability is generally measured by short period inter-train variability around the long-term trend and is little affected by the long-term variability.

The objectives of the operational mine planning model considered in this study are two-fold. First, the coal quality requirements for a planning period must be met, subject to some physical and geological constraints, policies and mining methods. Secondly, the quantity requirements must ensure sufficient coal production.

This model, in general, is based on predicted information about the in-situ quality of the coal deposit. Consequently, production scheduling for the purpose of controlling coal quality, *e. g.*, sulfur, have to be based on the predicted data of the contemplated mining benches. The model uses zero-one programming formulation to select potential working benches in surface coal

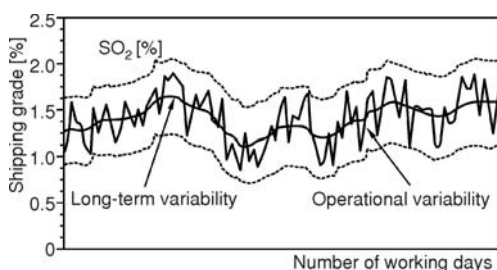

Figure 1. Long-term and operational variability of SO₂ grade

mine on the basis of predicted information. The standard optimisation technique widely used in many industrial applications is the linear and integer programming [12]. Models involve optimization of a quantity usually referred to as the objective function subject to a set of constraints which define the feasibility. In the operational mine scheduling, the decision to be made is which working benches should be mined. A decision variable (1) represents the i -th working bench and takes on a value of either zero (0) or one (1):

$$X_i = \begin{cases} 1 & \text{if } i^{\text{th}} \text{ working bench} \\ 0 & \text{if } i^{\text{th}} \text{ working bench is not mined} \end{cases} \quad (1)$$

with X_i denoting the i -th working coal bench whose predicted sulfur and tonnage values for a planned period, are sulfur (S_i , %) and coal production (T_i , tons), respectively, the objective function of an integer programming formulation of reducing total sulfur content is expressed by eq. (2):

$$\text{Minimize } \sum_{i=1}^n X_i S_i T_i, \text{ where } n \text{ is the total number of coal working benches} \quad (2)$$

The restriction with regard to both quality and tonnage requirements are formulated in the following way. First, run of mine composite sulfur (3) must not exceed maximum allowed, S_{\max} [%], during a shift (or period).

$$\frac{\sum_{i=1}^n X_i S_i T_i}{\sum_{i=1}^n X_i T_i} \leq S_{\max} \quad (3)$$

Also, all working bucket wheel excavators (BWE's) must mine coal during a period (or shift). This constraint (4) which guarantees a minimum production during a period, assumes that during any period, the available BWE's do not exceed the total number of potential working coal benches:

$$\sum_{i=1}^n X_i = BWE \quad (4)$$

In practice, the surface coal mine is divided into a number of mining phases, which are mined bench by bench, each bench represented by a horizontal layer of blocks within the given mining phase and having the same elevation. The mathematical formulation of the scheduling procedure of mining blocs in terms of binary decision variables describing in which period the particular block is extracted and what is its destination (either directly to the power plant or to processing plant and stockyard) is quite straightforward. But the hypothetical optimal block extraction sequence may be completely impractical due to the technological requirements for the mining equipment (BWE's) access and relocation.

Coal homogenization at the stockyard phase

Homogenization is stocking the ROM coal in layers, in their correct proportions, in the same stockpile, then reclaiming across the full face. In any blending pile the attenuation on variability depends on the equipment used and the way coal is stocked and reclaimed [6].

The main factors influencing blending efficiency are the pile size or its mass and the number of layers used to build pile. The aim in the homogenization process is to narrow down the standard deviation of the normal distribution. A measure of the quality of the homogenizing process is defined by the homogenizing efficiency (HE). In simplified terms, and subject to cer-

tain statistical assumptions, the resultant homogenizing effect is calculated as the variability of the incoming coal on pile (*e. g.* $S\%$) and the variability of the outgoing coal from pile [11]:

$$HE = \frac{\sigma_{in}}{\sigma_{out}} \cong 0.5\sqrt{n}, \text{ where } n \text{ is the number of layers} \quad (5)$$

By grouping exploitation mining blocks and forming a pile, the average grade of this pile is closer to the planned mean if compared to the grades of each individual block which comprise the pile. This phenomenon of variance reduction is well known and it is referred to as the volume-variance relationship [4, 5].

Prior to designing the homogenization stockyard it is necessary to know the sulfur content of coal that will form the pile. These grades come from a geological block model mined according to a sequence determined by an optimal mine scheduling. These block models however are obtained via classical interpolation algorithms, such as ordinary kriging. In these situations, the uncertainty associated with the interpolated value cannot be properly incorporated [9]. As a result of the so-called smoothing effect, the variance of the estimated values is smaller than that of the original data. There are also limitations associated with the use of the kriging variance as a measure of uncertainty [12].

The methodology suggested in this study quantifies the variability of the homogenization pile by using multiple equally probable realizations derived from a lognormally simulated sulfur distribution. Models used in this way, aim to replicate the spatial structure of a data set as a whole rather than provide reliable local estimates of an attribute at particular locations.

The stocking model

From operational mine plan the coal benches mined are forming each windrow stockyard pile. These multiple mining benches are an initial blending attempt as distinct coals are combined to ensure sulfur regularity minimum.

Software solution takes as input all needed design parameters, so very detailed analyses are possible. First input parameter is number of layers in base, from which software calculates total number of layers. There are n layers in the base. One can observe that there is an $n-1$ layer in the next row, but also that rhombus, and corner shaped layers are paired. So, in all non-base rows of layers, there is:

$$(n-1) + (n-2) + (n-3) + \dots + 1 = \frac{(n-1)n}{2}$$

pairs of square and corner shaped layers. Then total number of all base and non-base rows is:

$$n + 2 \frac{(n-1)n}{2} = n + n^2 - n = n^2 \quad (6)$$

The stockpile geometry is given with: length, width, height and slope are also input parameters. The software solution give possibility to define stockpile geometry (shape) with length, width, height and slope as input parameters, that provides easy adjustment for other, different stockpile size and shape. Another feature of interface is visualization of cross section for different stacking granularity, for selected pile and position within pile, fig. 2. The shadings of layer's cross-sections in fig. 2 are corresponding to the percentage of sulfur.

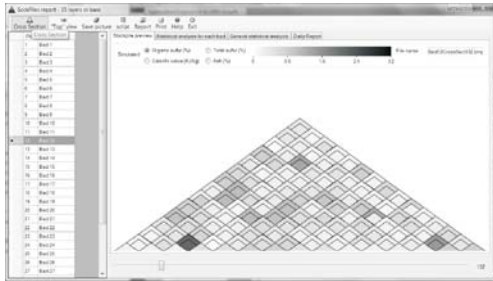

Figure 2. Software visualization of pile cross-section

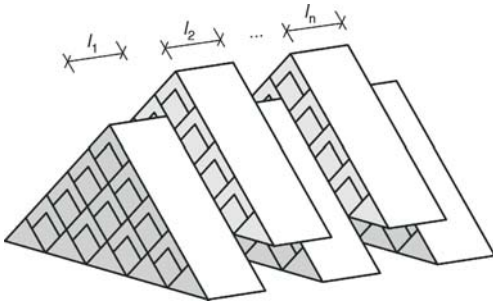

Figure 3. Reclaiming slices from windrow pile

range $[(j-1)d, jd]$ where d is the cut depth of the reclaimed. Now, the layers can be described by the matrix:

$$\begin{matrix} X_{11} & X_{12} & \cdots & X_{1n} \\ X_{21} & X_{22} & \cdots & X_{2n} \\ \vdots & \vdots & \ddots & \vdots \\ X_{m1} & X_{m2} & \cdots & X_{mn} \end{matrix}$$

where m is the number of stocked layers, l – the length of the bed, and $n = l/d$. The volume of the material reclaimed from layer i in cut j is denoted by v_{ij} . The average grade of material reclaimed in whole cut j is then computed by the formula:

$$\bar{X}_j = \frac{\sum_i v_{ij} X_{ij}}{\sum_i v_{ij}} \quad (7)$$

When necessary, calculation of volumes includes Monte Carlo integration for calculation of intersection area of arbitrary polygons when the polygons are too complex. We describe the Monte Carlo integration method we used. Let f be a function, and $I_V(f)$ the definite integral of that function:

$$I_V(f) = \int_{a_1}^{b_1} dX_1 \int_{a_2}^{b_2} dX_2 \cdots \int_{a_n}^{b_n} dX_n f(X_1, X_2, \dots, X_n) = \int_I f(\vec{x}) d\vec{x} \quad (8)$$

on the region of integration:

The reclaiming model

Developed reclaiming model determines the tonnage of coal to be loaded from stockyard piles by reclaimer, so that the total sulfur content of the reclaimed coal is minimised, while retaining its heating value within required range.

Bed blending assumes that each reclaim slice (fig. 3) includes equal amounts of material from all layers of material stacked. This is good approximation for some bed-blending systems, but it is not a good approximation for most mineral stockpiling systems. Therefore, we describe prediction of the performance of stockpiling systems for which reclaim slices include unequal amounts of material from the layers of material stacked, fig. 3.

Quality of the reclaimed material is calculated as the weighted average of pieces of the layers that are taken from the bed. In this calculation, each piece's quality is weighted by its volume. More precisely, let X_{ij} be the average grade of the material in layer i such that its distance from the beginning of the layer is in the

range $[(j-1)d, jd]$ where d is the cut depth of the reclaimed. Now, the layers can be described by the matrix:

$$V = [a_1, b_1] \times [a_2, b_2] \times \dots \times [a_n, b_n] \quad (9)$$

Monte Carlo approximation of this definite integral is calculated using:

$$A_n(f) = \frac{|V|}{N} \sum_i f(\bar{x}_i) \quad (10)$$

where $|V|$ is the volume of the integration region, and \bar{x}_i are the points in the random sample taken from the integration region. The value $A_n(f)$ converges to true value $I_V(f)$ as n goes to infinity. The variance of this estimate is calculated as:

$$\text{Var}[A_n(f)] = |V|^2 \frac{\text{Var}(f)}{n} \quad (11)$$

Since the variation of an integral able function is bounded, the variance of the estimate decreases as $1/(n)^{1/2}$.

Now, let $C_p(X)$ be the characteristic function of the polygon P . For each point, this function gives value 1 if that point is in the polygon and value 0 if the point is out of the polygon. This function can be calculated by taking an arbitrary ray (half-line) from the point that intersects the sides of the polygon. If the number of intersections is even, then the value of the function is 0, and if it is odd, the value of the function is 1. By plugging this function in the general formula for Monte Carlo integration, one can approximate the area of the polygon. In order to calculate the intersection of the polygons P_1, P_2, \dots, P_n , one should use the characteristic function of the intersection which is the product of characteristic functions of polygons, namely, $C_{P_1}(X)C_{P_2}(X)\dots C_{P_n}(X)$. Nevertheless, in most cases, the volume can be calculated exactly – without approximation.

Simulation methodology of coal quality control

The primary objective of the simulation is to determine a sequence of mining tasks to deliver the required coal quality and quantity to the power plants in the short-to-medium term. Simulation algorithms currently used in mining are more appropriate than ordinary kriging to deal with matters related to data variability. Mine production plans, scheduling, and blending strategies require knowledge of the dispersion of relevant geological attributes [8, 14]. Fluctuations in mining engineering and geochemical attributes of interest are also relevant for mine design and production scheduling. For example, mapping the probability of grades exceeding a limiting threshold within different areas of a deposit can warn of possible fluctuations in the grades, with direct implications on the scheduled mining plan.

Stochastic simulation model is used to generate multiple, equally probable scenarios of the phenomenon; each scenario reproduces the value of the sampled data, their spatial continuity, represented by lognormal model, and the histogram of the distribution, replicating the natural variability of the sulfur. These scenarios provide a set of possible values for each mining block, which form a homogenization pile. So, we generate many values for the average of blending piles studied as there are various possible scenarios generated by the simulation algorithm used.

Generation of dataset for this case study was performed in statistical package Rsim [15], with *rlnorm* function which can generate random numbers whose distribution is lognormal, with arguments: the number of random numbers, the mean and standard deviation. The following code was used:

$$ss_mean = 0.465; ss_stdev = 0.351; ss_meanlog = \log(ss_mean) - \frac{1}{2} \log\left(1 + \frac{s_stdev^2}{s_mean^2}\right)$$

$$ss_sdlog = \sqrt{\log\left(1 + \frac{s_stdev^2}{s_mean^2}\right)}; y = rlnorm(1, ss_meanlog, ss_sdlog)$$

The steps involved in the study can be summarized as:

- (1) Build a consistent geological database using drill holes and use this data to develop Minex™ coal quality seam models to map the variability associated with the *in situ* qualities. Generation of multiple equally probable models via Rsim.
- (2) After its construction, a mini block model is used for mining planning and scheduling. For a given mining schedule and multiple simulated quality models, compose the average content values for each pile system considering the number of blocks forming each chosen stockpile and their respective qualities. Each generated pile is based on a scheduled sequence of blocks forming the pile.
- (3) Plot the standard deviation from stockyard pile qualities in relation to planned average for various pile sizes (masses). Check the size of the pile, which leads to an acceptable range of content variation. Repeat (2) and (3) for each of several simulated models of sulfur contents to map the influence of *in situ* qualities uncertainty on the interpile quality fluctuation.

Case study

The case study uses data from a coal deposit located in Kolubara surface mine, fig. 4. The operating mining plan uses for grade estimation the original geological dataset. The local geology of mine includes 3 coal seams interbedded with waste material such as siltstones, sandstones, shales, and other sedimentary rocks. Available samples include 1118 heating values and 632 sulfur values for analysis distributed in the coal seams mentioned. The samples considered for this study were separated by coal seams. Samples were collected and analyzed at different length or support as each coal seam has thickness variations from point to point.

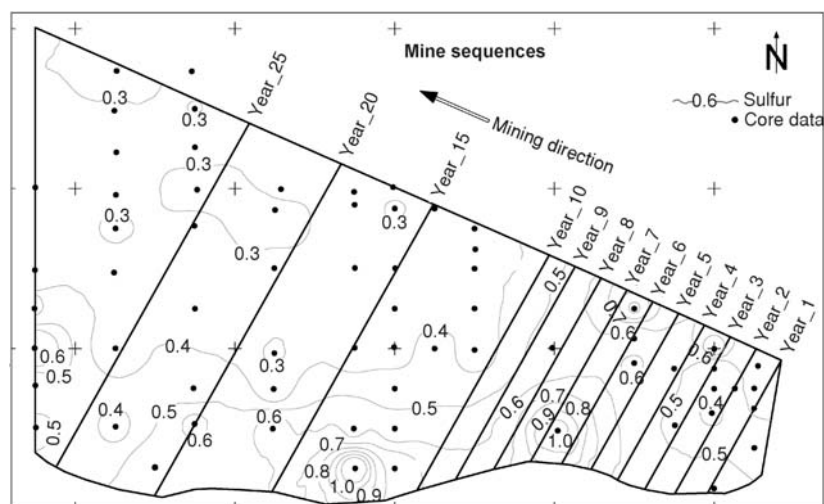

Figure 4. Field to be mined and the strip sequence by years

The Kolubara surface mine used for simulation is bounded by a rectangle, and mine sequencing is developed using the coal within the rectangle (fig. 4). The box cut is a planned start at the northern extreme of the area due to several technical operational reasons including an adequate location for the topsoil provisional deposit from the first cut. The area to be mined over the life of the mine was divided into 28 strips, 200 m wide. The deposit used to illustrate the methodology has 3 mineable coal seams, each with its own coal quality and own average thickness. To compose the sulfur grade value for mining blocks, it is necessary to combine multiple sulfur grade values from each different coal seam and multiple working benches.

Analyses has shown in Kolubara surface coal mine some parts of deposit with high content of organic sulfur, over 2% (see fig. 7). Adjusted on share of 95 percentiles content of sulfur is over 1%, although content in most of parts of the deposit is under 0.4%. The space distribution of sulfur required the homogenization of coal according to sulfur as a leading parameter. Slave parameter for homogenization is coal heating value. The integral model for coal quality control is developed and consists of three sub-models: operational mine scheduling model, stocking model and reclaiming model, fig. 5.

According simulated daily or shift mine plan each BWE has working bench position and production parameters. Mass and quality control will be done by on-line devices and weightmeters on main belt conveyor. If coal quality has required values coal is transported directly to thermal power plant, if not coal is transported on stockyard. Stacking and reclaiming will be controlled by its models.

To proceed with the pile simulator, a mining sequence associated to the mine plan is required. Mean of sulfur content at each stockyard pile directly depends on the coal block extraction schedule. This sequence is determined by a planned mine advance. Before starting the stocking and the analysis on the variability reduction with the increase of the number of stockyard pile layers, it is necessary to understand all variability sources influencing the pile homogenization system of the case study, namely:

- variability of the sulfur grades from each coal seam and bench₁₁, bench₁₂, ... bench_{ij}.
- variability of the sulfur grades, which feed the stockyard (pile combining coal from several mining benches or mines)
- variability among grades in homogenization piles (variability depending on number of layers).

In this study we use a pile of 350.000 t equivalent to new designed stockyard at the mine corresponding to 84 mining blocks from the model. Piles were designed as 48 m wide and

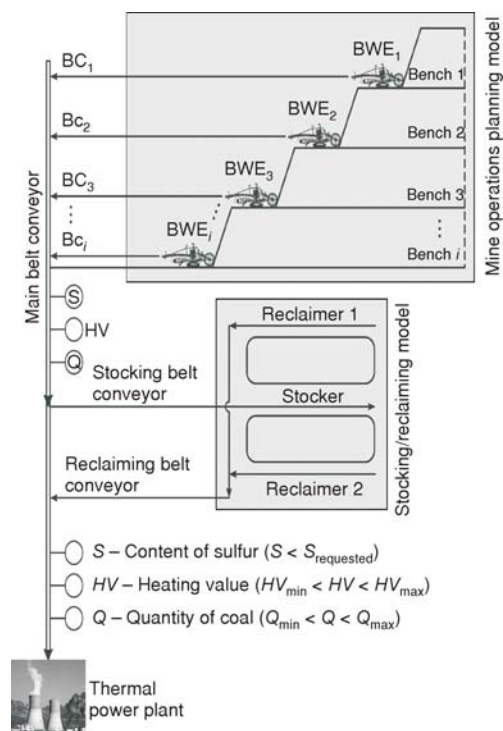

Figure 5. Technological scheme of coal homogenization in Kolubara surface mine

same length according to the variable number of layers. To illustrate the procedure, the blocks selected corresponded to the first year of production with a total of 4895 blocks. Each block has a grade obtained by *Rsim*, which, of course, differs among them and is different from the global mean calculated for the first year. By grouping various blocks and forming a pile, the average grade of this pile is closer to the global annual mean when compared to the grades of each individual block which comprise the pile, fig. 6.

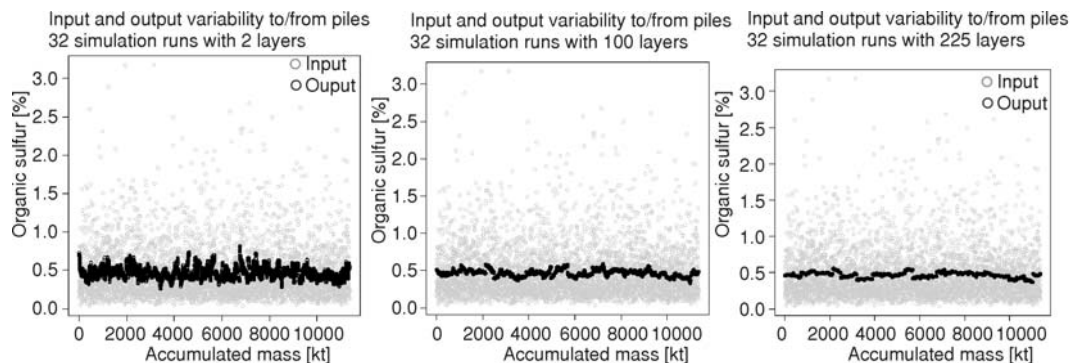

Figure 6. Simulation results for input/output variability of organic sulfur on pile

In this case study, we analyzed the performance of the homogenization method for various blending bed sizes. As illustration we present the variability of input and output data for the cases of 25, 100, and 169 layers in each bed. Gray circles represent the input data, horizontal axis corresponding to the cumulative mass of the coal stacked up until the moment, and vertical axis corresponding to the percentage of organic sulfur. Black circles represent the percentage of organic sulfur after the homogenization. One can notice that the output consists of several segments with rather small intersegment variation. Each segment corresponds to one reclaiming cycle. The mean values of segments vary inevitably as the trend changes in the input data.

This explains why the grades in the reclaimed coal from the piles led to a variance reduction in the grades feeding the power plants as compared to the grade variability that would be obtained from a mining block by block scheme feeding the power plant. A few other aspects controlling the variance of the average grades among stockpiles are:

- the larger the size of stockpile the smaller will be the variance of the average grade of each pile around the planned mean grade, and
- as a consequence of the stockpile size an extremely large pile hypothetically perfectly homogenized formed by all blocks mined during planned period would lead to a zero variance around the mean grade of this period (in theory).

However, the larger the pile the better will be the homogenizing process; and from an operational point of view the problems tend to grow in difficulty as the size of the stockyard equipment involved increases. The adequate pile size is the minimum size which will deliver coal to the plant with grades varying within a pre-determined and acceptable grade interval.

Given all information necessary from operational mine planning and scheduling to the stockyard simulation model, *i. e.* simulated block values and mining sequence, the average sulfur values of the homogenization piles can be obtained. The variability among piles was deter-

mined for variable number of layers in the same pile size. It was taken into consideration that the mass of each mined coal block is equivalent to BWE capacity on each coal seam.

Figure 7 shows that the simulated model adequately reproduced the histogram of the declustered original data. Left part of the figure is plotted the histogram of the original samples and in the right part the generated histogram by the algorithm of sequential lognormal simulation for one geological domain studied.

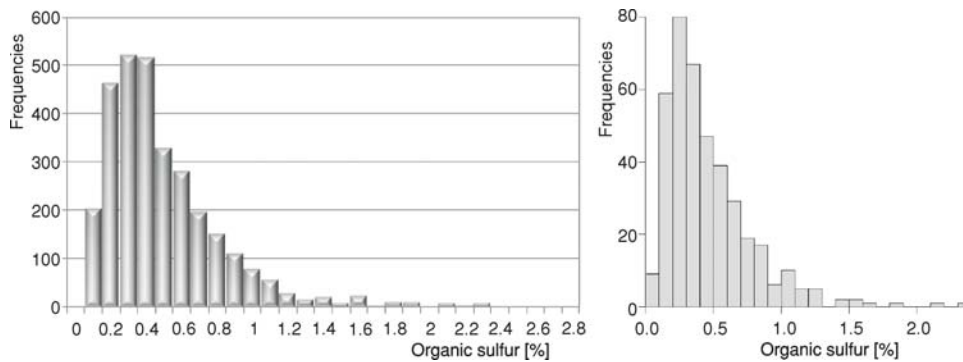

Figure 7. Histograms for sulfur original data (left) and (d) to simulated values of sulfur (right)

Given the validated simulated block model and the planned mining sequence, it is possible to calculate a set of equally probable values for the sulfur average that each blending pile can take. A pile is formed by a set of blocks from different mine faces from multiple benches. The scenarios generated by sequential Gaussian simulation would provide a group of possible values to the blocks that form a homogenization pile. Consequently, the average organic sulfur content calculated for each pile can assume as many values as simulated scenarios.

The algorithm developed considers the number of layers in piles and the contribution that each seam from each block adds to the total mass of the pile. When the number of layers and mass (size) of the pile is reached the algorithm stops, takes the weighted average of the qualities from the blocks included in this specific pile, and starts building the next pile.

Average standard deviations for the organic sulfur from various pile sizes is given in fig. 8. The figure illustrates the results obtained for the intrapile standard deviation for each number of layers tested. Note, the curves were plotted for all simulation runs constructing piles of 350.000 t and repeated 32 times (one for each simulated number of layers). It is noticed that after 100 layers the standard deviation stabilizes. The curves with the fitted (thick), minimum, average and maximum (dashed) standard deviations *vs.* the number of layers were highlighted. Horizontal axis refers to the number of layers. Vertical axis refers to the standard deviation. An exponential curve was fitted to these experimental points. The model derived for the standard deviation of organic sulfur *versus* number of layers is shown.

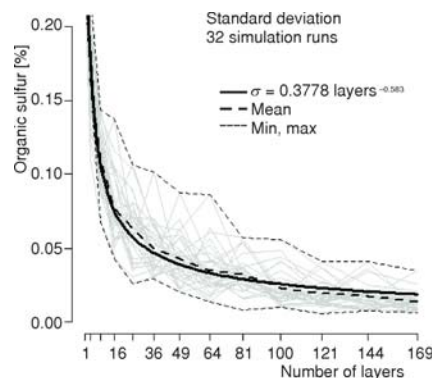

Figure 8. Average standard deviation for variable pile sizes

Conclusions

This paper reviewed homogenization methods used in stockyards and proposed a methodology to generate equally probable models based on maps of sulfur content within a coal deposit in Kolubara surface mine. These models allow assessing the uncertainty associated with the grade content in the ROM coal supplied to the power plant. As the size (mass) of the pile increased, the quality fluctuations reduced allowing the decision maker the choice of selecting a proper pile size to meet an acceptable level of variability. The optimal size must be defined taking into account capital and operational costs. The key message of stemming from the results in this paper is that the simulation model provides a useful decision support tool to compare operational mine scheduling and stockyard piles policies for controlling coal quality. According to the model, it is possible to reduce the variability of the grades exponentially as the mass of the pile increases.

Acknowledgments

The research outlined in this paper was supported by the Serbian Ministry of Education, Science and Technological Development of the Republic of Serbia, Belgrade grant # TR 33039.

References

- [1] ***, International Energy Outlook 2011, US Energy Information Administration, 2011
- [2] Ignjatović, D., *et al.*, *Coal Quality Management*, Faculty of Mining and Geology, University of Belgrade, Belgrade, 2007
- [3] Shih, J. S., Frey, H. C., Coal Blending Optimization under Uncertainty, *Proceedings*, Tenth Annual International Pittsburgh Coal Conference, Pittsburgh, Penn., USA, 1993, pp. 1110-1115
- [4] David, M., *Developments in Geomathematics 2: Geostatistical Ore Reserve Estimation*, 1st ed., Elsevier, Amsterdam, The Netherlands, 1977
- [5] Parker, H., The Volume Variance Relationship: A Useful Tool for Mine Planning, *Engineering and Mining Journal*, 180 (1979), 10, pp. 106-123
- [6] Schofield, C. G., *Homogenisation/Blending Systems Design and Control for Minerals Processing*, TransTech Publications, Rockport, Mass., USA, 1980
- [7] ***, A Review of the State-of-the-Art in Coal Blending for Power Generation, Final Report – Project 3.16., Coordinating Research Council, Algharetta, Geo., USA, 2001
- [8] Kim, Y. C., *et al.*, Development of Emission Control Strategies Using Conditionally Simulated Coal Deposits, University of Arizona, Tucson, Ariz., USA, Proprietary report prepared for the Homer City Owners, Homer City, Penn., USA, 15478, 1981
- [9] Costa, J. C. L., *et al.*, Incorporating in Situ Grade Variability into Blending Piles Design Using Geostatistical Simulation, *Proceedings*, 3rd World Conference on Sampling and Blending, Porto Alegre, Brasil, vol. 1, 2007. pp. 378-390
- [10] Gershon, M. E., Mine Scheduling Optimization with Mixed Integer Programming, AIME Fall Meeting, Honolulu, Hi., Preprint No. 82- 324, 1982
- [11] Padberg, M. W., *Linear Optimization and Extensions*, Springer, N. Y., USA, 1995
- [12] De Wet, N., Homogenizing/Blending in South Africa – An update, *Bulk Solids Handling*, Issue no.1, 1994
- [13] Isaaks, E. H., Srivastava, R. M., *Applied Geostatistics*, Oxford University Press, New York, USA, 1989
- [14] Bivand, R., *et al.*, *Applied Spatial Data Analysis with R. Use R Series*, Springer, Heidelberg, Germany, 2008
- [15] Murphy, T. D., Brown, K. E., Combining Geostatistics and Simulation to Predict Sulphur at a Central Illinois Coal Mine, *Mining Engineering*, 45 (1993), 3, pp. 284-287

Paper submitted: February 1, 2013

Paper revised: February 10, 2013

Paper accepted: April 4, 2013