

OPTIMIZATION OF THE TRIPLE-PRESSURE COMBINED CYCLE POWER PLANT

by

Muammer ALUS and Milan V. PETROVIĆ*

Faculty of Mechanical Engineering, University of Belgrade, Belgrade, Serbia

Original scientific paper
DOI: 10.2298/TSCI120517137A

The aim of this work was to develop a new system for optimization of parameters for combined cycle power plants (CCGT) with triple-pressure heat recovery steam generator (HRSG). Thermodynamic and thermo-economic optimizations were carried out. The objective of the thermodynamic optimization is to enhance the efficiency of the CCGT and to maximize the power production in the steam cycle (steam turbine gross power). Improvement of the efficiency of the CCGT plants is achieved through optimization of the operating parameters: temperature difference between the gas and steam (pinch point) and the steam pressure in the HRSG. The objective of the thermo-economic optimization is to minimize the production costs per unit of the generated electricity. Defining the optimal pinch point was the first step in the optimization procedure. Then, through the developed optimization process, other optimal operating parameters (steam pressure and condenser pressure) were identified. The developed system was demonstrated for the case of a 282 MW CCGT power plant with a typical design for commercial combined cycle power plants. The optimized combined cycle was compared with the regular CCGT plant.

Key words: combined cycle, heat recovery steam generator, thermodynamic optimization, thermo-economic optimization

Introduction

The heat recovery steam generator (HRSG) is one of the most important components of a combined cycle power plant (CCGT) that significantly affect the efficiency and the cost of the whole plant. The HRSG is an interface between the gas cycle and the steam cycle in a CCGT. Here, the exhaust gas from the gas turbine is cooled and the extracted heat is used to generate steam. In order to improve the heat recovery in the HRSG, more than one pressure level is used. With a single-pressure HRSG, about 30% of the total plant output is generated in the steam turbine. A dual-pressure arrangement can increase the power output of the steam cycle by up to 10%, and an additional 3% can be achieved with a triple-pressure cycle [1]. Modern combined cycle power plants with a triple-pressure HRSG with steam reheat can easily reach thermal efficiencies above 55% [1].

* Corresponding author; e-mail: mpetrovic@mas.bg.ac.rs

Several studies have carried out thermodynamic and thermoeconomic optimizations of CCGT. Valdes *et al.* [2] performed a thermoeconomic optimization of combined cycle gas turbine power plants using a genetic algorithm. They proposed two different objective functions: one minimizes the cost of production per unit of electricity and the other maximizes the annual cash flow. Attala *et al.* [3] optimized a dual pressure level CCGT. They worked with a simulation program that included three modules: the first simulates the cycle, the second evaluates the thermodynamic and thermoeconomic parameters and the third is the optimization model. Kumar *et al.* [4] studied the effect of HRSG configuration of both single pressure and dual pressure on combined cycle power plant efficiency by using first law and second law of thermodynamics. They discussed the effect of various parameters like pinch point (PP), approach point; steam pressure, steam temperature, and gas flow rate on the performance of the HRSG by using energy and exergy analysis. Behbahani-nia *et al.* [5] presented an exergy based thermoeconomic method, which is applied to find optimal values of design parameters (the PP and gas-side velocity) for a specific HRSG used in combined cycle power plants. Ahmadi *et al.* [6] have thermodynamically analyzed a combined cycle power plant with a supplementary firing system through energy and exergy. The optimal design of operating parameters of the plant is then performed by defining an objective function and applying a generic algorithm (GA) type optimization method. Valdes *et al.* [7] presented a method for optimization of an HRSG based on the utilization of influence coefficients, which takes advantage of the influence of the design parameters on the cycle thermodynamic performance, although its application to multiple pressure configurations becomes complex because of the need to evaluate a large number of combinations.

In this work, we assume that the parameters of the gas at the gas turbine outlet (*i. e.* the mass flow $\dot{m}_{GT,out}$ and the temperature $T_{GT,out}$) are fixed and they are used as input data for optimization of the HRSG. Two different types of optimization of the HRSG, thermodynamic and thermoeconomic optimization were performed. The subject of both optimizations was the cycle operating parameters: PP, steam drum pressures and condenser pressure. These parameters have greater effects on the cost of the HRSG than the all other operating parameters together [2]. The PP represents the difference between the gas temperature leaving the evaporator and the saturation temperature [5]. In the past, authors have used their experience to select a value for the PP for thermodynamic and thermoeconomic optimization. In that respect, the PP was usually selected in the range of 5-15 K [8]. However, our idea was first to find the optimal value of the PP delivering minimal production costs of electricity, and then to optimize the other operating parameters (steam drum pressures and condenser pressure) keeping the optimal value of the PP constant. A comparison between an initial case and an optimization case was made in order to test the model and the methodology. To perform a power plant optimization a cost hypothesis for all components of the plant had to be assumed.

Thermodynamic optimization model

The objective of thermodynamic optimization is to enhance the efficiency of the CCGT and to maximize the electrical power in the steam cycle (steam turbine gross power). Here, a CCGT cycle with a triple-pressure HRSG will be considered. This case is the most complex one. The same procedure can be applied for single-pressure or dual-pressure of the HRSG CCGT. Figure 1 shows a schematic diagram of the triple-pressure HRSG for a combined cycle power plant. The assumptions and parameters selected for the thermodynamic analysis of the plant are tabulated in tab. 1.

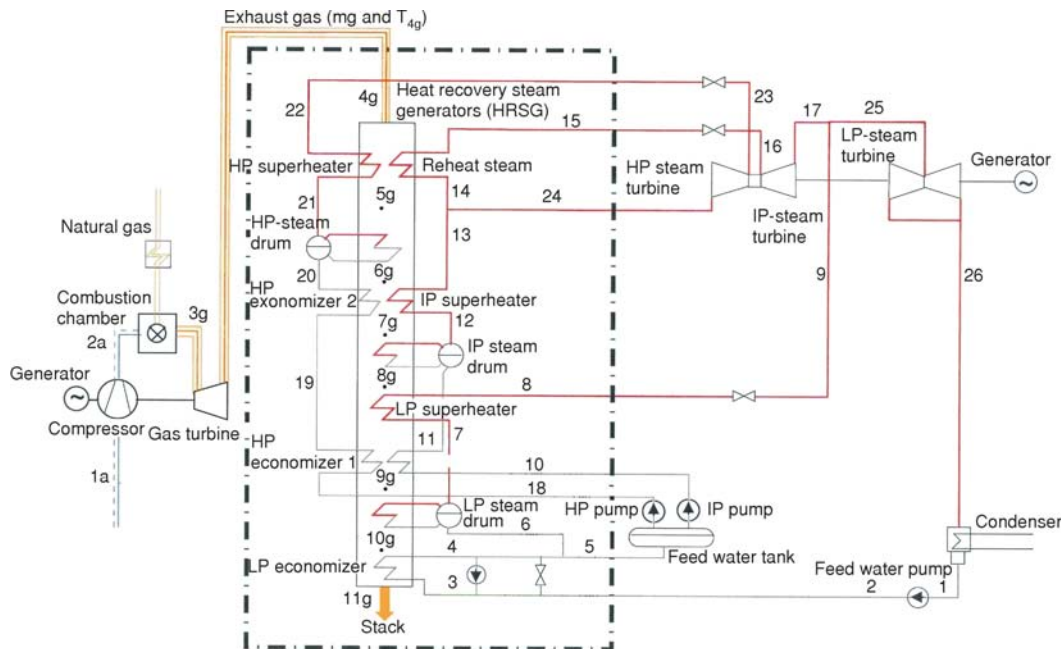

Figure 1. Gas turbine and steam turbine combined cycle – heat balance diagram

Table 1. Gas turbine parameters and assumptions for component performances of the CCGT with the triple-pressure HRSG selected for the optimization

Parameter	Value
<i>Gas turbine cycle (Alstom GT24/1994)</i>	
Ambient air pressure [bar]	1.013
Ambient air temperature [°C]	15
Relative humidity	0.60
Electrical power at the generator output [MW]	187.7
Exhaust gas mass flow [kgs ⁻¹]	445
Exhaust gas temperature at the gas turbine outlet [°C]	612
The gas turbine efficiency [%]	36.9
Lower heat value of the fuel [kJkg ⁻¹]	47141
Minimum stack temperature [°C]	100
<i>Assumption</i>	
The isentropic efficiency of all three steam turbine parts	90%
The isentropic efficiencies of water pumps	82%
The mechanical efficiency	99.5%

Table 1 (continuation)

The generator efficiency	98%
The heat recovery steam generator efficiency [9, 10]	99.3%
The pressure drops for water in the economizers [10]	25%
The pressure drops for steam in the reheat and superheater tubes [10]	8%
The overall heat transfer coefficients for sections of the HRSG [$\text{Wm}^{-2}\text{K}^{-1}$] [1]	42.6
– economizer	43.7
– evaporator	50
– superheater and reheat	
The minimum temperature difference between the gas turbine exhaust gases and live/reheat steam [$^{\circ}\text{C}$]	25
Minimum dryness fraction of steam at low steam turbine outlet [9]	0.88
Low-pressure steam turbine outlet (condenser pressure) [bar]	0.055
The inlet cooling water temperature in condenser [$^{\circ}\text{C}$]	20
Feed water temperature at 3 [$^{\circ}\text{C}$]	60

Energy balance of HRSG sections

The water-steam properties were derived from the standard “IAPWS” 97 [11]. The properties of the gas turbine exhaust gases, which are combustion products of the specified fuel, were calculated according to Baehr *et al.* [12]. The compute code to calculate the heat balance of triple-pressure HRSG CCGT was developed in FORTRAN 90. To find the optimum, the PP was varied stepwise from 3 to 40 $^{\circ}\text{C}$ and heat balance of the plant, the overall efficiency and gross power output were calculated for every step. The values for PP in all of the three pressure HRSG parts are considered as equal.

The temperature of the gas entering the LP economizer, IP economizer, and HP economizer can be written as follows:

$$T_{6g} = T_{20} + PP \quad (1)$$

$$T_{8g} = T_{11} + PP \quad (2)$$

$$T_{10g} = T_6 + PP \quad (3)$$

After the thermodynamic properties of water-steam in all steam cycle points have been calculated, the mass flow rate of steam generation in the HRSG can be determined by applying the energy balances for flow at each single pressure. The energy balance equation for the high-pressure part of the HRSG gives:

$$\dot{m}_{\text{GT,out}} \eta_{\text{HRSG}} (h_{4g} - h_{6g}) = \dot{m}_{\text{ST,HP}} [(h_{22} - h_{20}) + (h_{15} - h_{24})] + \dot{m}_{\text{ST,IP}} (h_{15} - h_{13}) \quad (4)$$

where $\dot{m}_{\text{GT,out}}$ and $\dot{m}_{\text{ST,HP}}$, $\dot{m}_{\text{ST,IP}}$ are the mass flow rates of gas and steam, respectively, entering sections 1 and 2. h_{4g} and h_{13} , h_{24} are the enthalpies of gas and steam entering section 1, h_{20} – the enthalpy of steam entering section 2, h_{15} and h_{22} are the enthalpies of steam at the exit of section 1 and is the enthalpy of gas at the exit of section 2.

Applying the energy balance equation for the intermediate-pressure part of the HRSG yields:

$$\dot{m}_{GT,out} \eta_{HRSG} (h_{6g} - h_{8g}) = \dot{m}_{ST,HP} (h_{20} - h_{19}) + \dot{m}_{ST,IP} (h_{13} - h_{11}) \quad (5)$$

where h_{6g} is the enthalpy of gas entering section 3, h_{8g} – the enthalpy of gas at the exit of section 4, h_{11} – the enthalpy of steam entering section 4, and h_{13} , h_{20} are the enthalpies of steam at the exit of section 3.

The application of the energy balance equation for the low-pressure part of the HRSG gives:

$$\dot{m}_{GT,out} \eta_{HRSG} (h_{8g} - h_{10g}) = \dot{m}_{ST,HP} (h_{19} - h_{18}) + \dot{m}_{ST,IP} (h_{11} - h_{10}) + \dot{m}_{ST,LP} (h_8 - h_6) \quad (6)$$

where h_{8g} and h_{10} , h_{18} are the enthalpies of gas and steam entering section 5, h_6 is the enthalpy of steam for the entire section 6, h_8 , h_{11} and h_{19} are the enthalpies of steam at the exit of section 5 and h_{10g} is the enthalpy of gas at the exit of section 6.

To find the total steam mass flow, the mass balance equation for the HRSG is applied:

$$\dot{m}_{ST} = \dot{m}_{ST,HP} + \dot{m}_{ST,IP} + \dot{m}_{ST,LP} \quad (7)$$

The temperature of gas leaving sections 1 of the HRSG, T_{5g} , is determined from the energy balance for this section:

$$h_{5g} = h_{4g} - \frac{\dot{m}_{ST,HP} [(h_{22} - h_{21}) + (h_{15} - h_{13})] + \dot{m}_{ST,IP} (h_{15} - h_{24})}{\dot{m}_{GT,out} \eta_{HRSG}} \quad (8)$$

The temperature of gas leaving sections 3, 5, and 7, T_{7g} , T_{9g} , and T_{11g} , are determined in a similar manner to T_{5g} .

Calculation of the heat transfer area

In the present work, the HRSG model is assumed to be counter flow heat exchanger. The area A of HRSG necessary to ensure the heat transfer at a given PP was calculated according to Rovira *et al.* [13]. The heat transferred through each area of HRSG is given by:

$$\dot{Q}_i = U_{m,i} A_i LMTD_i \quad (9)$$

where A refers to the heat exchange area and U_m is average overall heat transfer coefficient.

The log mean temperature difference (LMTD) is calculated as:

$$LMTD_i = \frac{\Delta T_{1,i} - \Delta T_{2,i}}{\ln \frac{\Delta T_{1,i}}{\Delta T_{2,i}}} \quad (10)$$

where ΔT_1 is the temperature difference between gas and steam at the inlet of the heater and ΔT_2 – the temperature difference between gas and steam at the exit of the heater.

The HRSG net heat transfer area is calculated as sum of the necessary heat transfer area for each steam pressure level:

$$A_{HRSG} = \sum_E A_E + \sum_V A_V + \sum_{SH} A_{SH} + \sum_{RE} A_{RE} \quad (11)$$

The condenser heat transfer area A_{cond} was calculated according to [14]:

$$A_{cond} = \frac{\dot{Q}_{cond}}{U_{cond} LMTD_{cond}} \quad (12)$$

where \dot{Q}_{cond} is the heat transferred and U_{cond} – the heat transfer coefficient in condenser.
The condenser log mean temperature difference, $LMTD_{\text{cond}}$, is defined as:

$$LMTD_{\text{cond}} = \frac{TR}{\ln \frac{1}{1 - \frac{TR}{ITD}}} \quad (13)$$

where TR is the temperature rise of cooling water in the condenser and ITD – the difference between the steam temperature and cooling water inlet temperature (the initial temperature difference).

Combined cycle efficiency

The overall cycle efficiency can be obtained from the steam and gas turbine powers, which are dependent not only on the HRSG area, but also on many other variables such as condenser pressure, pressure drum, and ambient temperature:

$$\eta_{\text{CCGT}} = \frac{W_{\text{ST}}(\dot{m}_{\text{ST}}, h_{\text{cond}}, \eta_{\text{ST}}) + W_{\text{GT}}}{\dot{m}_f H_t} \quad (14)$$

For the initial case, the typical values for PP and for HP, IP and LP drum were selected. The results of heat balance calculation are presented in tab. 2. The results of the initial case will be compared with the results of the optimized case.

Table 2. Initial case – Results of the thermodynamic analysis

Parameter	Value
<i>Steam turbine cycle</i>	
The pinch point temperature difference for HP, IP and LP [°C]	13
Live steam pressure (HP) [bar]	104
Live steam temperature at the inlet of the HP steam turbine [°C]	545
Pressure of reheat steam (IP steam turbine) [bar]	36
Temperature of the reheat steam (IP steam turbine) [°C]	545
Pressure of the inlet LP steam turbine [bar]	5
Temperature of the superheated steam at 8 [°C]	235
Temperature of the superheated steam at 13 [°C]	325
Steam mass flow [kgs ⁻¹]	70
– High-pressure steam mass flow [kgs ⁻¹]	52.5
– Intermediate-pressure mass flow [kgs ⁻¹]	10.5
– Low-pressure mass flow [kgs ⁻¹]	7
Steam turbine gross power [MW]	94.6
<i>Combined cycle power plant</i>	
Combined cycle gross power [MW]	282.3
Combined cycle efficiency [%]	55.5

Thermoeconomic optimization model

The goal of thermoeconomic optimization is to minimize the production costs of electricity of the plant.

Main thermoeconomic characteristics of CCGT

The thermoeconomic optimization was performed under the following conditions, which were chosen according to experience and the current market conditions:

- (1) The average life of the combined cycle power plant is 20 years.
- (2) The power plant is in operation 7500 hours a year.
- (3) Price of natural gas is $c_f = 0.0467$ \$/kWh.
- (4) The installed costs of the economizer, evaporator, superheater, and reheat sections of the HRSG are 45.7, 34.8, 96.2, and 56.2 \$/m², respectively, [1].

Functions of component capital costs

The basic problem in the analysis of the economic effectiveness of investments in energy systems is the determination of capital costs. For this study the cost functions for the major components of a combined cycle power plants were taken from literature: cost of gas turbine C_{GT} [15], cost of HRSG C_{HRSG} [5], cost of steam turbine C_{ST} [16], cost of condenser C_{cond} [3], cost of pump C_{pump} [16], and cost of generator C_{gen} [16].

The cost functions give net capital costs of the components. However, the net capital cost does not include: transport and assembly costs, supervising, accessories, engineering and project management, commissioning, and other connected costs. Therefore, the additional correction factor R was introduced in eq. 15 to cover these additional costs and increase in price in the recent period. The R value is obtained by analysis and consulting the market. In the calculations, the value of R is assumed to be 3.0.

The total capital costs (investment costs) of a CCGT are given by:

$$C_{CCGT} = R \sum_i C = R(C_{GT} + C_{HRSG} + C_{ST} + C_{cond} + C_{pump} + C_{gen}) \quad (15)$$

The cost function of HRSG, steam turbine, condenser, pump and generator in eq. 15 is expressed as a function of the operating parameters (PP, HP, IP, LP, and P_{cond}). Therefore, any change in these variables will cause a change in the total capital costs.

Objective function

The objective of the optimization is a minimization of production costs of electricity in the CCGT power plant.

The production cost of electricity is the ratio between the total cost per year and the total annual energy production $W_{CCGT,h}$ [2, 17]:

$$C_{kWh} = \frac{C_{tot}}{W_{CCGT,h}} \quad (16)$$

The total cost per year includes the fuel cost, the amortization cost and the operating and maintenance cost:

$$C_{\text{tot}} = C_{\text{Tf}} + C_a + C_{\text{o\&m}} \quad (17)$$

The total fuel cost C_{Tf} could be found from:

$$C_{\text{Tf}} = c_f \left(\frac{W_{\text{CCGT}}}{\eta_{\text{CCGT}}} \right) h \quad (18)$$

The amortization cost C_a that accounts for the total fixed cost divided by the plant economic lifetime is:

$$C_a = \frac{C_{\text{CCGT}}}{N} \quad (19)$$

The annual operating and maintenance cost $C_{\text{o\&m}}$ is assumed to be 10% of the total plant cost [17]:

$$C_{\text{o\&m}} = 0.10 C_{\text{tot}} \quad (20)$$

Results and discussion

The optimization procedure

The aim of this study was to develop a simple procedure for optimizing of five most influential CCGT parameters: PP, HP, IP, LP drum and condenser pressure. Here, a 4-step procedure is developed.

In the first step, the experience-based values for the pressure of the HP, IP, and LP drum are selected and held constant during this step. In our case, the values for HP, IP, and LP drum were taken to be the same as in the initial case. The value for the PP is varied in the range of 3 to 40 °C in steps of 0.5 °C. The thermodynamic parameters and thermoeconomic parameters are calculated. The optimal value for the PP is determined based on the steam turbine gross power *i. e.* the production cost of electricity.

In the second step, for the determined optimal value of PP, we seek optimal values for HP, IP, and LP drum by varying one parameter while keeping the other three parameters constant. For example, the HP drum was varied in the range of 100 to 200 bar, while the PP and the IP and LP drum were kept constant. Based on the calculated production cost of electricity, the optimal value for HP drum is determined. The procedure is then repeated for IP and LP drum.

In the third step, the mutual influence of individual parameters is checked in an iterative procedure. For example, the selection of PP (step 1) is repeated with the new, improved values for HP, IP, and LP drum. Then, with the new, optimal value for the PP and the new, improved steam pressure in the HRSG, the procedure for selection of the HP, IP, and LP drum is repeated. The procedure converges quickly and gives the final solution in a few iterations.

In the proposed method, the steam drum pressures (HP, IP, and LP drum) were varied as following: HP drum is from 100 to 200 bar, IP drum is from 32 to 50 bar and LP drum is from 1 to 4.25 bar.

Once the optimum values of the HRSG operating parameters was determined, the pressure condenser was varied in the range of 0.04 to 0.08 bar and then the optimization procedure is repeated (the fourth step).

Results of the thermodynamic optimization

Figure 2 shows the effect of PP variation on the combined cycle gross power. The results show the combined cycle gross power decreases with increasing value of the PP. A decrease in the PP will significantly increase the necessary HRSG area and, therefore, the cost (capital cost of devices), as defined in eq. 15. It is easy to conclude that the maximum efficiency and maximum steam turbine gross power will be reached at a null value for PP and infinite heat transfer surface (HRSG area). In order to find a compromise between maximum CCGT gross power and low cost of the HRSG, thermo-economic optimization was also performed.

Figure 3 shows the combined cycle gross power as a function of HRSG high pressure drum. It was found out that there is no upper limit value of the HP drum. This means that the combined cycle gross power increases with increasing HP drum.

Figure 4 shows the combined cycle gross power as a function of HRSG intermediate pressure drum. The result shows that the combined cycle gross power decreases with increase in IP drum.

The dependence of the combined cycle gross power on HRSG low-pressure drum is

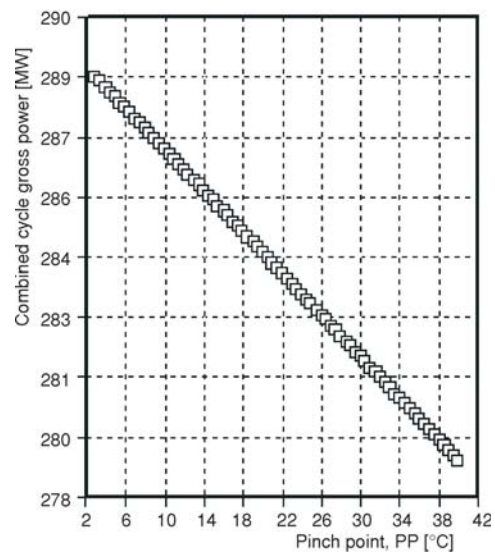

Figure 2. Effect of PP variation on the combined cycle gross power

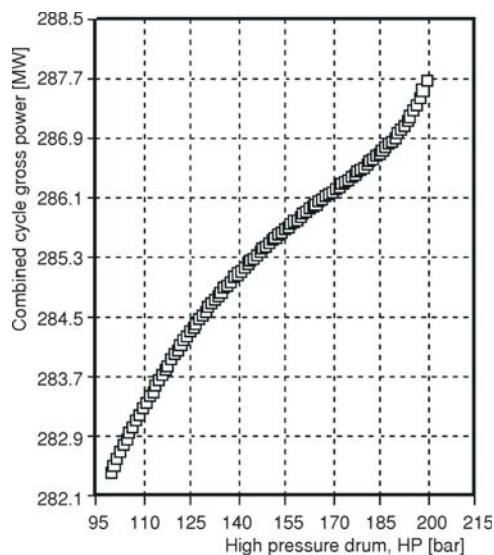

Figure 3. Combined cycle gross power at optimal PP as a function of HRSG high drum pressure

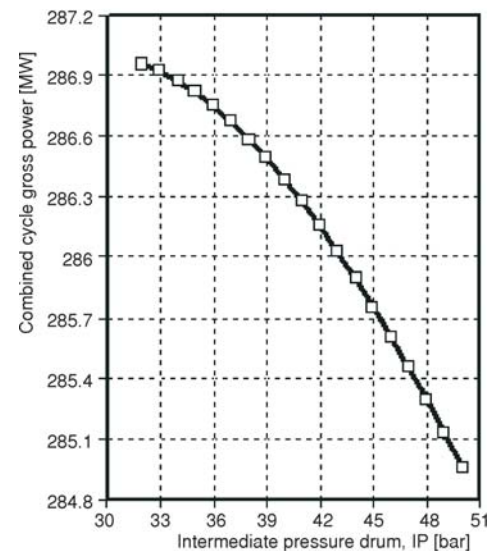

Figure 4. Combined gross power at optimal PP as a function of HRSG intermediate drum pressure

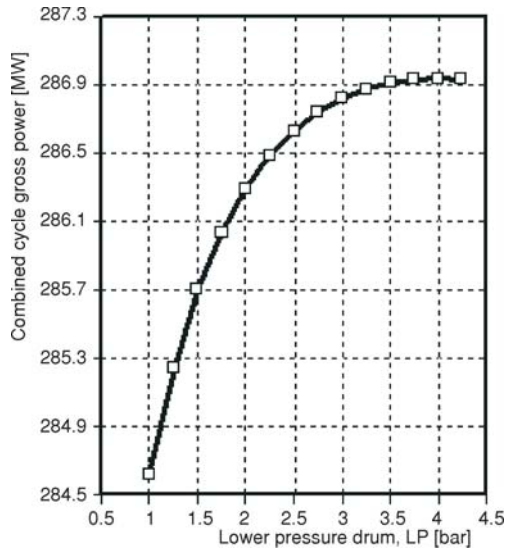

Figure 5. Combined cycle gross power at optimal PP as a function of HRSG low pressure drum

presented in fig. 5. The results show that the combined cycle gross power increases with increase in LP drum until 4 bar and then the combined cycle gross power decreases with increase in LP drum. The maximum CCGT gross power is at 4 bar.

Results of the thermoeconomic optimization

Figure 6 shows the effect of PP variations on the production cost of electricity, which is defined by eq. 16 for a CCGT with a triple-pressure HRSG. The production cost of electricity decreases with an increase in the PP until it reaches the optimal value and then increases with further increases in the PP. The results show that the optimal value for the PP, at which the minimum production cost of electricity C_{kWh} is achieved, is 9.5 °C. The calculated value seems reasonable based on what is suggested by experience. However, the optimum value of the

PP strongly depends on the cost hypothesis.

Figures 7, 8, and 9 show the effect of variations in the HP, IP, and LP drum on the production cost of electricity C_{kWh} . From the previous figures, it may be seen that, for this case, the major parameter that affects the efficiency is the pinch point, while the steam pressures in HRSG have more effect on the production cost of electricity. It can be observed that for all three steam pressures, which were the subject of optimization, there is an optimal value at which the best re-

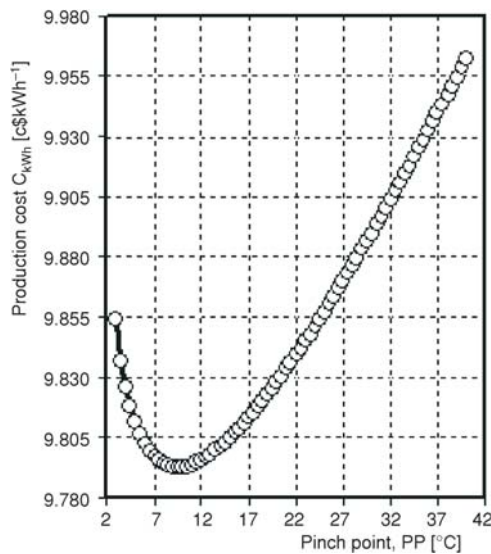

Figure 6. Effect of PP variations on the production cost of electricity

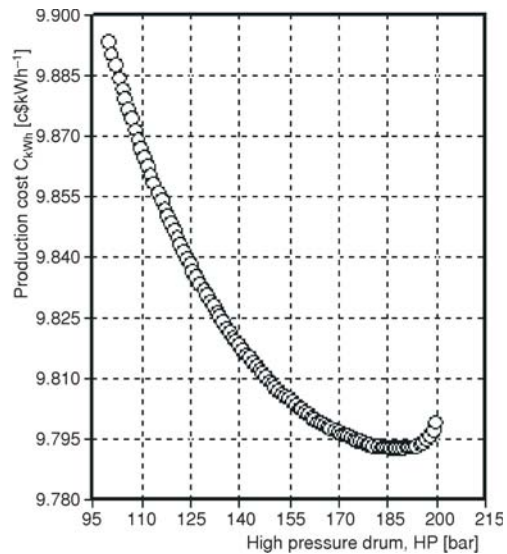

Figure 7. Effect of HP drum variations on the production cost of electricity

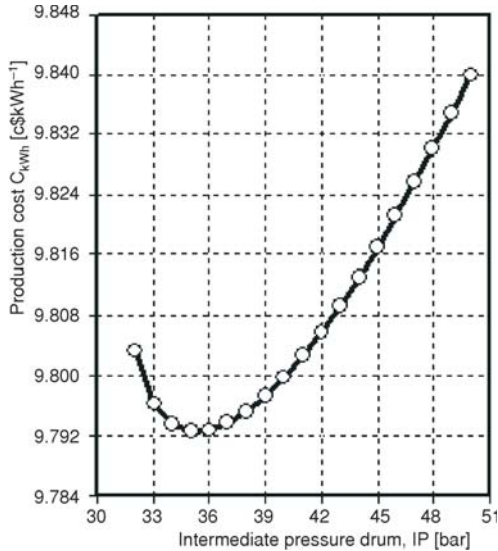

Figure 8. Effect of IP drum variations on the production cost of electricity

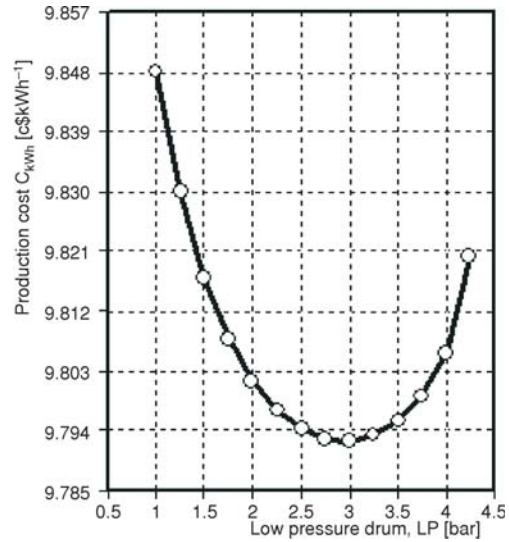

Figure 9. Effect of LP drum variations on the production cost of electricity

sults can be achieved. These values are 188 bar for HP drum, 35 bar for IP drum, and 3 bar for LP drum.

Analyzing these results, it can be seen that for HP drum a higher value is obtained in the optimized case (188 bar) then it was in the initial case (104 bar). With a fixed steam turbine inlet temperature due to material restrictions, the increased high pressure steam drum (HP) in the triple-pressure HRSG will have two major effects. First, an increase in pressure will change the distribution of heat between the economizer and the superheater. Secondly, a higher pressure steam drum goes hand in hand with a higher evaporation temperature and, hence, the HRSG PP is moved up along the flue-gas line. On other hand, the optimization identified lower value for LP drum than was used in the initial case and the optimum value for IP drum is not so far from the initial case.

The increased costs for HRSG due to increase in the initial costs for the HP-level (area, piping, material, *etc.*) are covered by a larger production of electricity and better overall efficiency value

Figure 10 shows the effect of the condenser pressure P_{cond} on the production cost of electricity C_{kWh} . As can be seen, production cost of electricity decreases with an increase in the P_{cond} , until it reaches the optimal value and then

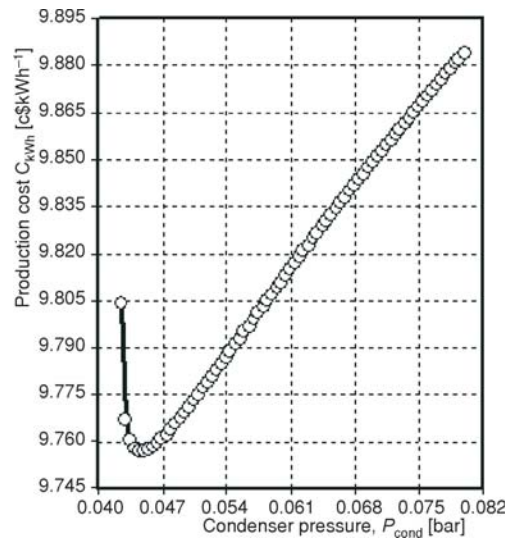

Figure 10. Effect of P_{cond} variations on production cost of the electricity

increases with further increase in the P_{cond} . The result shows that the optimal value for the P_{cond} , at which the minimum production cost of electricity C_{kWh} is achieved, is 0.045 bar.

Table 3 shows a comparison of the results for the initial case and optimized case. The results show that the financial parameters are significantly better than the initial case. Thermoeconomic optimization intend to achieve a trade-off between enhance the efficiency and minimum production costs of electricity. In our case, applying the developed method the efficiency of the selected combined cycle could be increased by about 1.2% and the electrical output by more then 6 MW. On the other hand, the production costs of electricity were decreased by 0.12 cent-dollar per kilowatt-hour by optimal selection of the parameters.

Table 3. Comparison between the initial case and the optimized case

Parameter	Initial case	Optimized case
Pinch point (PP)	13 °C	9.5 °C
High pressure drum (HP)	104 bar	188 bar
Intermediate pressure drum (IP)	36 bar	35 bar
Low pressure drum (LP)	5 bar	3 bar
Condenser pressure (P_{cond})	0.055 bar	0.045 bar
Combined cycle-efficiency (η_{CCGT})	55.5%	56.7%
Combined cycle-gross power (W_{CCGT})	282.3 MW	288.4 MW
Production cost (C_{kWh})	9.88 c\$/kWh	9.76 c\$/kWh

Conclusions

A new method for thermodynamic and thermoeconomic optimization of triple-pressure combined cycle power plants was presented in this paper. The aim of these optimizations was to improve the performances of power plants. Thermodynamic analysis provided a zero pinch point (*i. e.* infinite evaporators surfaces) for optimum, as expected. Also, the optimal value for steam pressures could not be found from the thermodynamic optimization.

The proposed thermoeconomic optimization procedure considers, in addition to the thermodynamic parameters, also the economic effectiveness through the calculated economic parameters. The optimal operating parameters in the thermoeconomic optimization were identified with the aim to minimize the production cost of electricity. Through an interactive procedure, the mutual influences of the parameters were taken into account. The results of the thermoeconomic optimization have shown that optimal settings for the operating parameters can be found.

The developed thermoeconomic method is successfully applied to an example. The optimization procedure used in this study led to a significant improvement in the economic parameters. Compared with the initial case, the production cost was decreased by 0.12 c\$/kWh. It can be concluded that the proposed optimization method could be used instead of that based on the a priori choice method, as it is more comprehensive and reliable.

The results obtained here depend strongly on the gas turbine selection and cannot be extrapolated to other CCGT power plant because of the complexity and large number of possible power plant configurations

Further investigations should use optimization algorithms to study both the triple-pressure HRSG and the steam cycle operating parameters.

Nomenclature

A	– heat transfer area, [m ²]	R	– correction factor for componetns cost, [-]
C	– cost, [\$]	T	– temperature, [K or °C]
c_f	– price of the fuel, [\$/kWh ⁻¹]	U	– overall heat transfer coefficient, [kWm ⁻² K ⁻¹]
H_l	– lower heat value of the fuel, [kJkg ⁻¹]	W	– power, [MW]
h	– specific enthalpy, [kJkg ⁻¹]	η	– efficiency, [-]
h	– number of operating hours of the plant per year, [hour]		
$LMTD$	– log mean temperature difference, [°C]		
\dot{m}_{ST}	– steam mass flow rate, [kgs ⁻¹]		
$\dot{m}_{ST,HP}$	– high-pressure steam mass flow rate, [kgs ⁻¹]		
$\dot{m}_{ST,IP}$	– intermediate-pressure steam mass flow rate, [kgs ⁻¹]		
$\dot{m}_{ST,LP}$	– low-pressure steam mass flow rate, [kgs ⁻¹]		
$\dot{m}_{GT,out}$	– gas turbine exhaust mass flow rate, [kgs ⁻¹]		
mf	– fuel mass flow rate, [kgs ⁻¹]		
N	– economic life of the plant, [year]		
P	– pressure, [bar]		
PP	– pinch point (PP) temperature difference, [°C]		
\dot{Q}	– heat transferred, [kW]		

Subscripts

CCGT	– combined cycle power plant
cond	– condenser
E	– economizer
GT	– gas turbine
HP	– high pressure
HRSG	– heat recovery steam generator
IP	– intermediate pressure
LP	– low pressure
Out	– outlet from the gas turbine
RE	– reheat
ST	– steam turbine
SH	– superheater
V	– evaporator

References

- [1] Casarosa, C., Donatini, F., Franco, A., Thermoeconomic Optimization of Heat Recovery Steam Generators Operating Parameters for Combined Plants, *Energy*, 29 (2004), 3, pp. 389-414
- [2] Valdes, M., Duran, M.D., Rovira, A., Thermoeconomic Optimization of Combined Cycle Gas Turbine Power Plants Using Genetic Algorithms, *Applied Thermal Engineering*, 23 (2003), 17, pp. 2169-2182
- [3] Attala, L., Facchini, B., Ferrara, G., Thermoeconomic Optimization Method as Design Tool in Gas-Steam Combined Plant Realization, *Energy Conversion and Management*, 42 (2001), 18, pp. 2163-2172
- [4] Ravi Kumar, N., Rama Krishna, K., Sita Rama Raju, A. V., Thermodynamic Analysis of Heat Recovery Steam Generator in Combined Cycle Power Plant, *Thermal Science*, 11 (2007), 4, pp. 143-156
- [5] Behbahani-nia, A., Sayadi, S., Soleymani, M., Thermoeconomic Optimization of the Pinch Point and Gas-Side Velocity in Heat Recovery Steam Generators, *Journal of Power and Energy*, 224 (2010), 6, pp. 761-771
- [6] Ahmadi, P., Dincer, I., Thermodynamic Analysis and Thermoeconomic Optimization of a Dual Pressure Combined Cycle Power Plant with a Supplementary Firing Unit, *Energy Conversion and Management*, 52 (2011), 5, pp. 2296-2308
- [7] Valdes, M., Rapun, J., Optimization of Heat Recovery Steam Generators for Combined Cycle Gas Turbine Power Plants, *Applied Thermal Engineering*, 21 (2001), 11, pp. 1149-1159
- [8] Franco, A., Russo, A., Combined Cycle Plant Efficiency Increase Based on the Optimization of the Heat Recovery Steam Generator Operating Parameters, *International Journal of Thermal Science*, 41 (2002), 9, pp. 843-859

- [9] Bassily, A. M., Numerical Cost Optimization and Irreversibility Analysis of the Triple-Pressure Reheat Steam-Air Cooled GT Commercial Combined Cycle Power Plants, *Applied Thermal Engineering*, 40 (2012), pp. 145-160
- [10] Chiesa, P., Macchi, E., A Thermodynamic Analysis of Different Options to Break 60% Electric Efficiency in combined Cycle Power Plants, *Journal of Engineering for Gas Turbines and Power*, 126 (2004), 4, pp. 770-785
- [11] Wagner, W., Kruse, A., Properties of Water and Steam, IAPWS-IF97, Springer, Berlin, 1998
- [12] Baehr, H. D., Diederichsen, C., Equations for Calculation of Enthalpy and Entropy of the Components of Air and Combustion Gases (in German), *BWK*, 40 (1988), 1-2, pp. 30-33
- [13] Rovira, A., Valdes, M., Duran, M., A Model to Predict the Behavior at Part Load Operation of Once-Through Heat Recovery Steam Generators Working with Water at Supercritical Pressure, *Applied Thermal Engineering*, 30 (2010), 13, pp. 1652-1658
- [14] Li, K. W., Priddy, A. P., Power Plant System Design, John Wiley & Sons, Canada, 1985
- [15] Roosen, P., Uhlenbruck, S., Lucas, K., Pareto Optimization of a Combined Cycle Power System as a Decision Support Tool for Trading of Investment vs. Operating Costs, *International Journal of Thermal Sciences*, 42 (2003), 6, pp. 553-560
- [16] Silveira, J., Tuna, C., Thermoeconomic Analysis Method for Optimization of Combined Heat and Power Systems, Part I, *Progress in Energy and Combustion Science*, 29 (2003), pp. 479-485
- [17] Valdes, M., Rovira, A.V., Duran, M. D., Influence of the Heat Recovery Steam Generator Design Parameters on the Thermoeconomic Performance of Combined Cycle Gas Turbine Power Plants, *International Journal of Energy Research*, 28 (2004), 14, pp. 1243-1254