

EFFECT OF WAVY FIN USAGE ON THERMAL PERFORMANCE OF HEAT EXCHANGER USED IN COMBI BOILERS

Halit YAŞAR¹, Gülcan Özel EROL², Ufuk DURMAZ^{1}, Ahmet AYDIN³, Serhan KILIÇ⁴ and Tahsin ENGİN¹*

¹Sakarya University, Engineering Faculty, Mechanical Engineering Department, Sakarya, Turkey

²Bilecik S.E. University, Engineering Faculty, Mechanical and Manufacturing Engineering Department, Bilecik, Turkey

³Sakarya University, Engineering Faculty, Metallurgical and Materials Engineering Department, Sakarya, Turkey

⁴“Daikin Isıtma ve Soğutma Sistemleri San. Tic. A.Ş.”, R&D Department, Sakarya, Turkey

Corresponding author* E-mail: udurmaz@sakarya.edu.tr

In this study, performance of a heat exchanger used in combi boilers was investigated numerically for different fin geometries. Analyses were performed at the boiler operation conditions. A commercial computational fluid dynamics (CFD) software package (FLUENT) was used for numerical simulations. 3-D steady-state turbulent flow field analysis was carried out and k-ε model was preferred as the turbulence model. In the analysis, it was assumed that the heat transfer phenomenon occurred both by conduction and convection. Flat fin geometry was taken as a reference for the investigation. Variation of the heat transfer and pressure drop values for the wavy fin were compared with the reference geometry. The wave angle and wave radius were taken as the parameters for the wavy fins. For different fin geometries; the outlet temperature of the combustion gases, the heat transfer to the water and the pressure drop were calculated and the results were presented. Compared with flat fin, average decrease for the outlet temperature of hot gases was obtained as 4 K and average increase for the heat transfer to the water was calculated as 0,68 W. On the other hand, the average pressure drop in the heat exchanger with wavy fins was about 70% higher than the flat fin.

Key words: Heat Exchanger, Combi Boiler, Wavy Fin, CFD.

1. Introduction

The heat exchangers are widely used for various purposes, especially in industrial and residential applications with a high rate of energy consumption. For this reason, it is important to optimally design heat exchangers. Many studies have been carried out to enhance heat transfer by

active [1] and passive [2–5] methods, developing detailed prediction procedures for heat exchanger performance [6]. Some of them have been carried out to minimize the problems such as environmental factors, limited energy sources and high energy costs in improving heat exchangers. In these studies, it is aimed to achieve less power loss, higher heat transfer rate and improved compactness.

Wang et al. have experimentally investigated the performance of wavy fins in tubular heat exchangers. Eighteen samples with different fin geometry and pipe arrangement were used in the experiments which were in the wind tunnel ($400 \leq Re \leq 8000$). It has been observed that increases in the heat transfer coefficient and the friction factor were by; 55-70% and 66-140% respectively for wavy fins in comparison to the flat fins in the study [7]. The effect of fin profile and tube row number on the heat transfer performance for tubular heat exchangers with wavy and flat wings were studied numerically by Jang and Chen [8]. The range of Reynolds number was $400 < Re < 1200$ and 3-D model has been used for their study. It has been detected that the effect of the number of tubes in wavy fins was lower than that of flat fins and this effect was gradually reduced by the increase of Reynolds number. At constant wave length, as the wave angle increases, the mean Nusselt number and pressure coefficient were observed to increase. For the constant wave angle, the Nusselt number and the pressure coefficient was observed to decrease with increasing wave length [4]. Tao et al. [9] have investigated the heat transfer and flow characteristics of the air side with a three-dimensional manner in a finned tube type heat exchanger. For different wave angles, local Nusselt number, fin efficiency and temperature distribution were calculated. Junqi et.al. [10] examined the air-side thermal performance in a finned heat exchanger with flat water channels. The effect of the fin spacing, fin height and fin length parameters in the ($800 < Re < 6500$) flow conditions were determined using the NTU method in the study. They examined the performance of the fins in the form of flat, wavy and detonated lamella in analyzes in the FLUENT program in 3D. In heat transfer wavy wings compared to flat wings 12%, 26% improvement was achieved in fins in the form of detonated lamella. Pourahmad and Pesteei [11] have experimentally studied the effectiveness of a double tube heat exchanger equipped with wavy strip at various angles. Their results showed the considerable effect of turbulators on effectiveness and NTU of double heat exchanger. They also developed some empirical correlations expressing the results. When looking at the literature studies on wavy fin geometries in recent years [12–19], it can be seen that the subject still keeps up-to date.

In this study, it is aimed to model the heat exchanger used in combi boilers and to investigate the thermal performance for different fin geometries. Numerical analyses were performed by using ANSYS/FLUENT software [20], using the k- ϵ turbulence model combined with the standard wall functions for the near wall flow. Wavy fins are preferred as the fin geometry. The heat transfer and the pressure drop for the fins with different geometries were examined by changing the wave angle and radius of the curvature in the fin structure. By taking the fin thickness as constant and the distance between the fins into account, the data obtained from the wavy fins were compared with the flat fin profile.

2. Numerical procedure

The heat exchanger consists of two plates with fins on one side and water channels on the other side and a premixed burner with metal fiber wrap. Heat exchanger's dimensions are 116 mm x 193 mm x 270 mm.

For convenience in solving, models are designed to include two half-fins and the air volume between them. The models for the flat and wavy profile of the fin are given in Fig. 1.

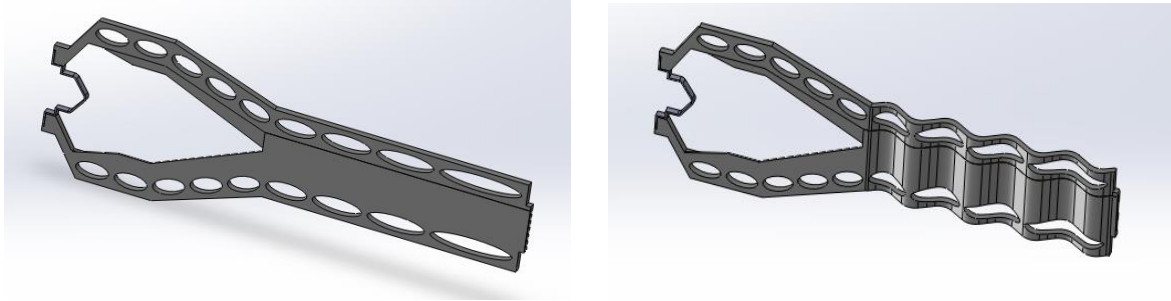

Figure 1. The flat and wavy fin models

The wavy fin profile is shown in Fig. 3. The fin thickness is 2 mm, the distance between the fins is 2 mm and the fin height is 28 mm.

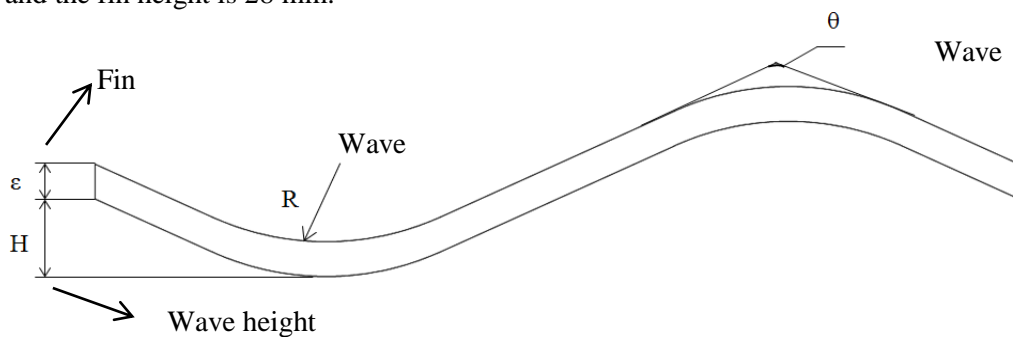

Figure 2. Wavy fin profile

In this study, aluminum was chosen as the fin material. The thermophysical properties of aluminum are given in Table 1.

Table 1. Thermophysical properties of aluminum

Density (kg/m ³)	2719
Specific heat (J/kgK)	871
Thermal conductivity (W/mK)	202.4

Mole fractions of the combustion gases and their properties were determined by using the following combustion equation. Excess air coefficient was taken as 1.247 in the equation.

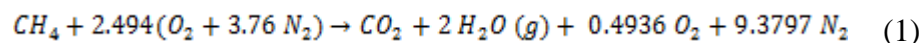

The variation of the specific heat of combustion gases with temperature is shown in Fig. 3. In order to consider this dependency in the numerical computations, a polynomial curve fit of 5th order is created and used.

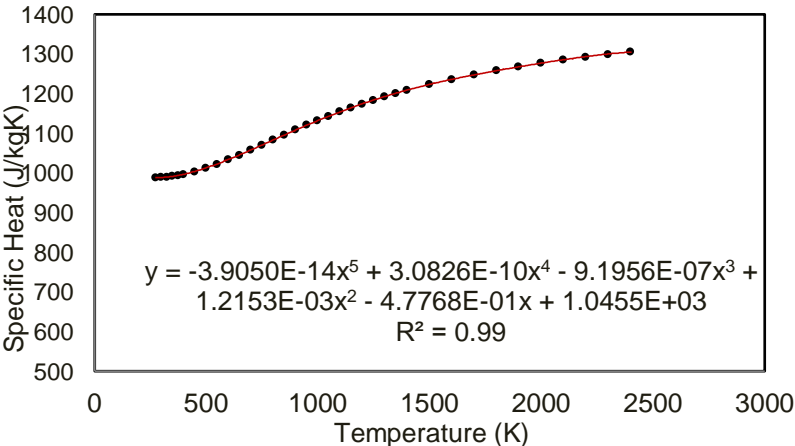

Figure 3. Variation of the specific heat of combustion gases

The Sutherland viscosity law was chosen for the viscosity of the combustion gases and the density was calculated with ideal gas assumption in the analysis. The boundary conditions applied on the solution model are shown in Fig. 4.

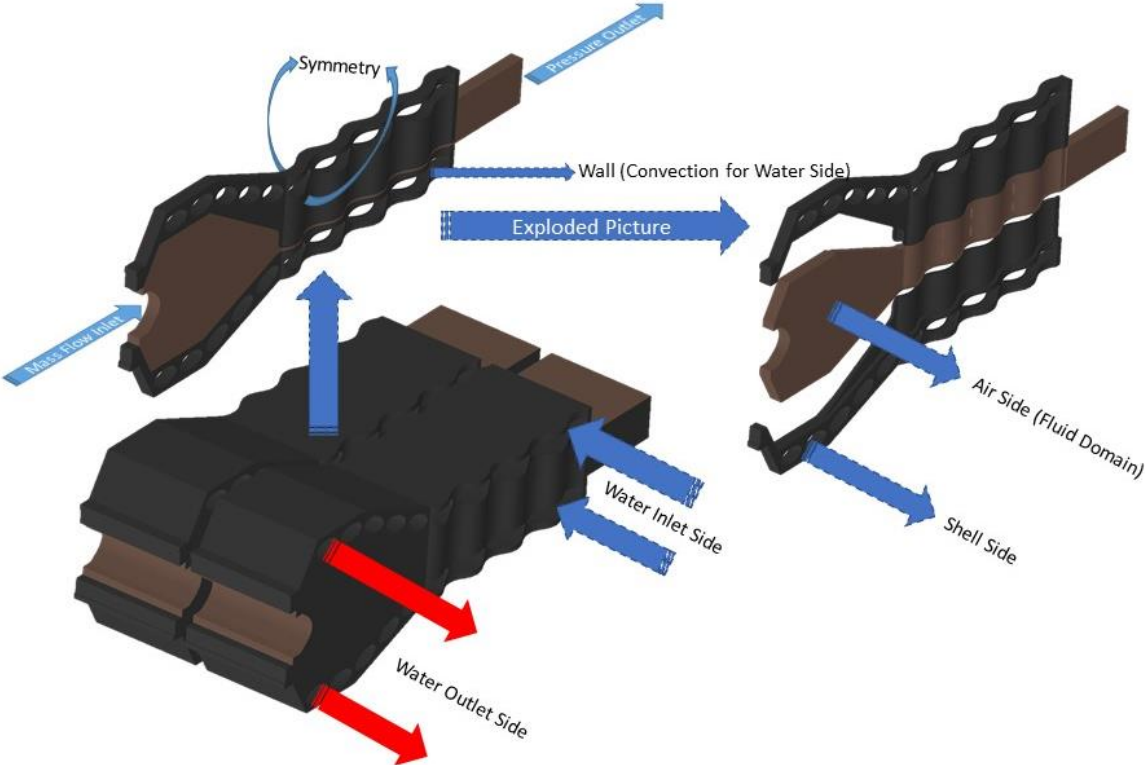

Figure 4. Boundary conditions

The mass flow inlet boundary condition was defined by selecting the burner inner surface. In the heat exchanger, combustion takes place in the burner surface. The adiabatic flame temperature was calculated by following equation [21].

$$\sum N_p(\bar{h}_f^o + \bar{h} - \bar{h}^o)_p = \sum N_r(\bar{h}_f^o + \bar{h} - \bar{h}^o)_r \quad (2)$$

The input mass flow rate was defined as 1.69×10^{-4} kg / s considering the operating conditions of the boiler at full load (24 kW). The outlet of the heat exchanger was defined as pressure outlet boundary condition. In order to facilitate the solution, symmetry boundary condition was applied to the model. Convection boundary condition was applied to the channel surfaces to calculate the amount of heat transfer to the water in the analyses. The free stream temperature was obtained as 343 K by taking the arithmetic average of the 333 K inlet of the water and the 353 K outlet of the water temperatures at the boiler test conditions.

Water side heat convection coefficient was calculated as $h = 6249.8$ W / m²K. Models have curved surfaces due to wavy structure. The fin thickness of the model is 1 mm. Therefore, it is important to define properly the element characteristics at this narrow distance. Consequently, "Proximity and Curvature" mesh module was preferred. Reliability of the CFD results is mostly related to the quality of mesh. The skewness value is another important parameter. In this study, total number of cells ranging about $1.5 \times 10^6 - 5.5 \times 10^6$ was tested for the same model and the results indicated that a quite good mesh was achieved with 4.5×10^6 cells.

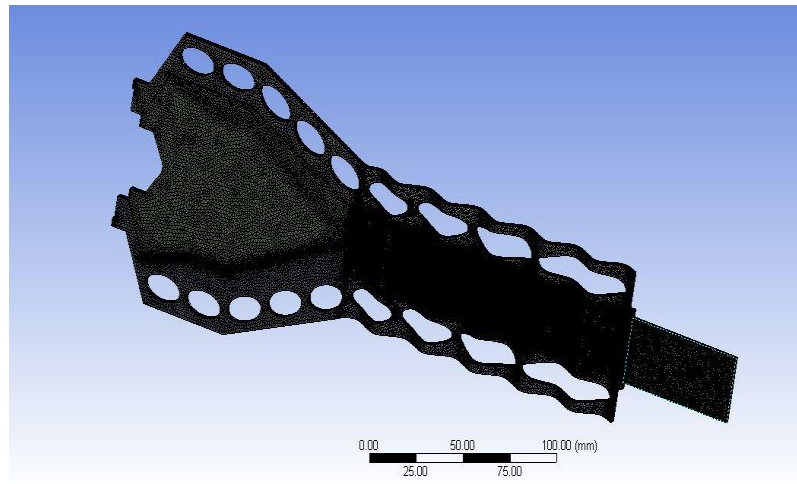

Figure 5. Numerical grid for the wave angle of 100° and wave radius of 10 mm

3. Results and discussion

In this article, the thermal performance of the wavy fin profile for a heat exchanger used in the combi boiler was compared to the flat fin profile of the same combi boiler. Twenty-six different fin profiles were generated by changing the wave angle and wave. Simulation results of the pressure drop, heat transfer rate, outlet temperature of the combustion gases, and temperature distribution are presented and discussed below.

3.1. Effect of wave radius on thermal performance

The combustion outlet gas temperatures in boilers are between 100 and 150 °C. In recent years, particularly together with the condensation technology, combi boilers have begun to utilize the thermal energy of the combustion outlet gases. These devices are intended to reduce the temperature of combustion outlet gases and to condense the water in the waste gas. For this reason, the combustion gas outlet temperature in the combi boilers has become an important design parameter. The effect of wave radius on the temperature of combustion outlet gases is shown in Fig. 6 for 7 different wave angles (95°, 100°, 105°, 110°, 116°, 123° and 130°). Fig. 7 shows the temperature distributions on fin

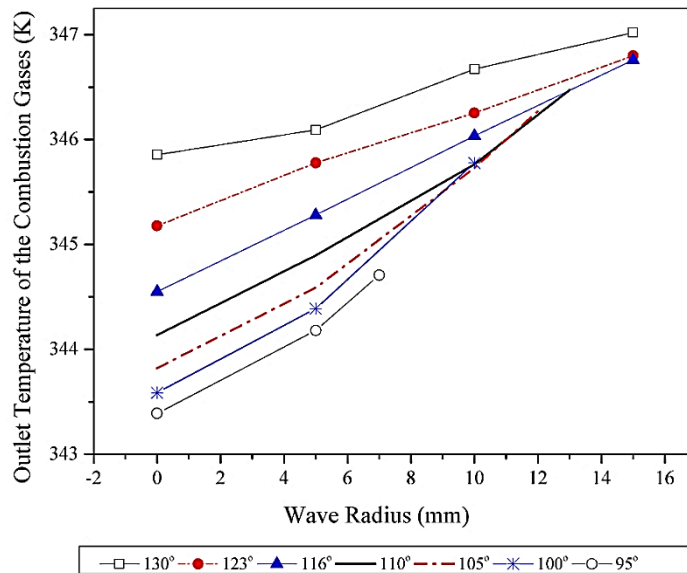

Figure 6. The combustion gas outlet temperatures with wave radius for different wave angles

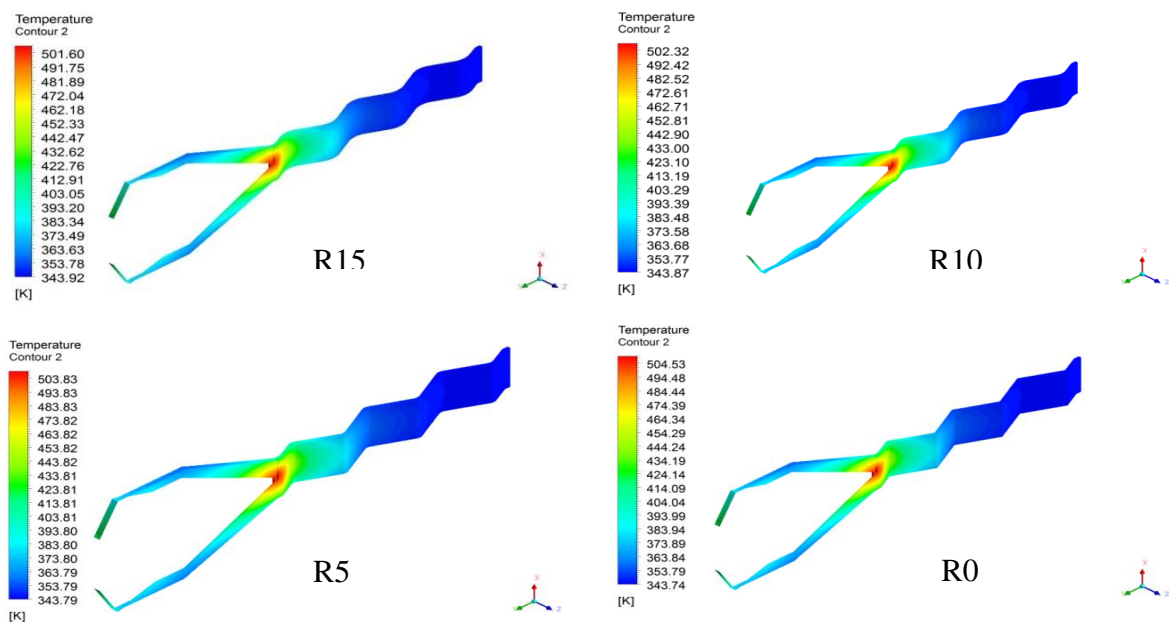

Figure 7. Temperature distribution on fins for 130° wave angle at different wave radius

profile for 130° wave angle at different wave radius. In the case of flat fin profile, combustion outlet temperature was obtained as 349.4 K. With the use of a wavy fin profile, this temperature decreased up to 4K. The outlet temperature of combustion gases increased with increasing the wave radius. The minimum combustion gas outlet temperatures were obtained with the zigzag fin profile, which has 0 mm wave radius, for all wave angles.

It is aimed to increase the convective heat transfer coefficient by techniques such as increasing the fluid velocity in the heat exchangers and using the extended surface. However, these applications increase the convective heat transfer coefficient and the pressure drop in the heat exchanger. This also increases the pump or fan power. As a result, the investment and the operating costs increase. With increased competition, it is aimed that the pump and additional energy costs due to pressure loss are at optimum level while the heat transfer performance is improved during the design process of the combi boilers. Simulation result of the pressure drop for the flat fin profile was obtained as 93.22 Pa. Variation of the pressure drop with wave radius for different wave angles is shown in Fig.8. It can be seen from Fig. 8 that the pressure drop increases as the wave diameter decreases in the wavy fins and the wave radius has a significant effect on the pressure drop. The use of wavy fin increased the pressure drop up to 70%. This pressure increase was obtained as 20% for R15 and 140% for R0 zigzag fin profile.

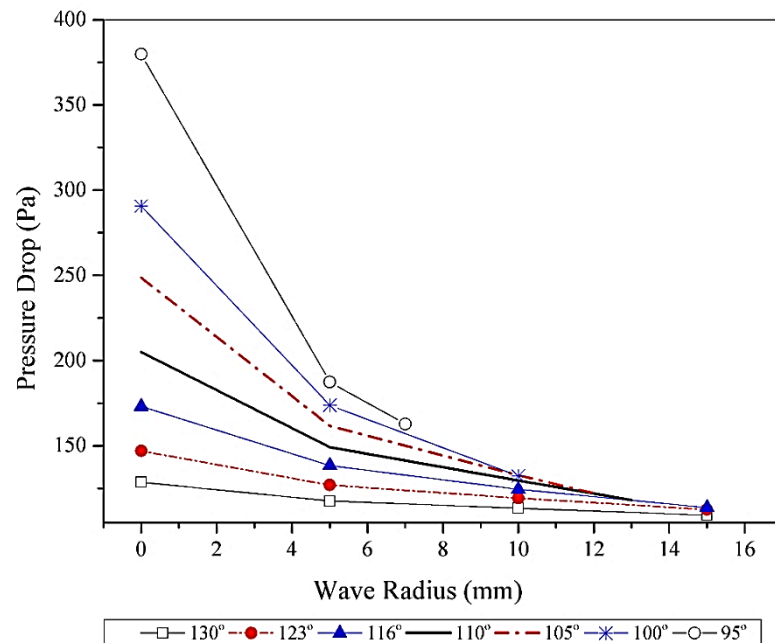

Figure 8. The pressure drop with wave radius for different wave angles

The variation of the amount of heat transferred to the water versus wave radius is given in Fig. 9 for different wave angles. When the wave radius is increased, the amount of heat transferred to the water decreases. The amount of heat transferred to the water for the flat fin profile was calculated as 354.35 W. The simulation results indicate that the amount of heat transferred to the water increase about 0.15% for R15 wave radius and 0.25% for R0 zigzag wave profiles.

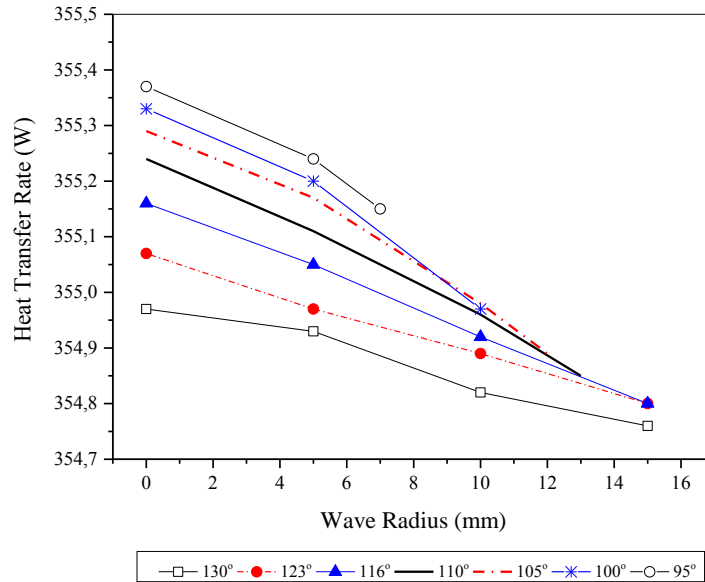

Figure 9. The heat transfer rate to the water versus wave radius for different wave angles

3.2. Effect of wave angle on thermal performance

The variation of the heat exchanger thermal performance versus fin angle was investigated for 130°, 123°, 116°, 110°, 105°, 100° and 95° wave angles. The variation in combustion outlet temperatures versus wave angle is shown in Fig. 10 for three wave angles. Fig. 11 shows the temperature distributions for zigzag fin profile at different wave angles. It can be seen from the Fig. 10 that the outlet temperature of the combustion gases increases with the increase in wave angle. The increase of wave angle reduces the fin density in the wavy fins. Therefore, the heat transfer rate decreases and the outlet gas temperature increases. Between 100° and 130° wave angles, this reduction was 2.5 K in zigzag fin profile and 1 K in the fins with a 15 mm wave radius.

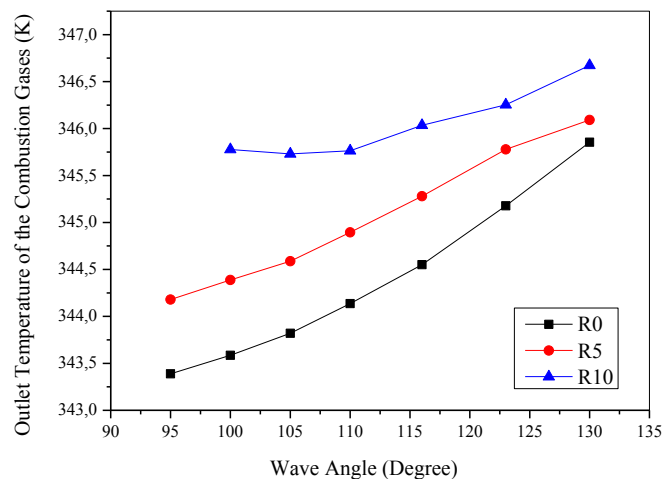

Figure 10. Combustion gas outlet temperatures with wave angle at different wave radius

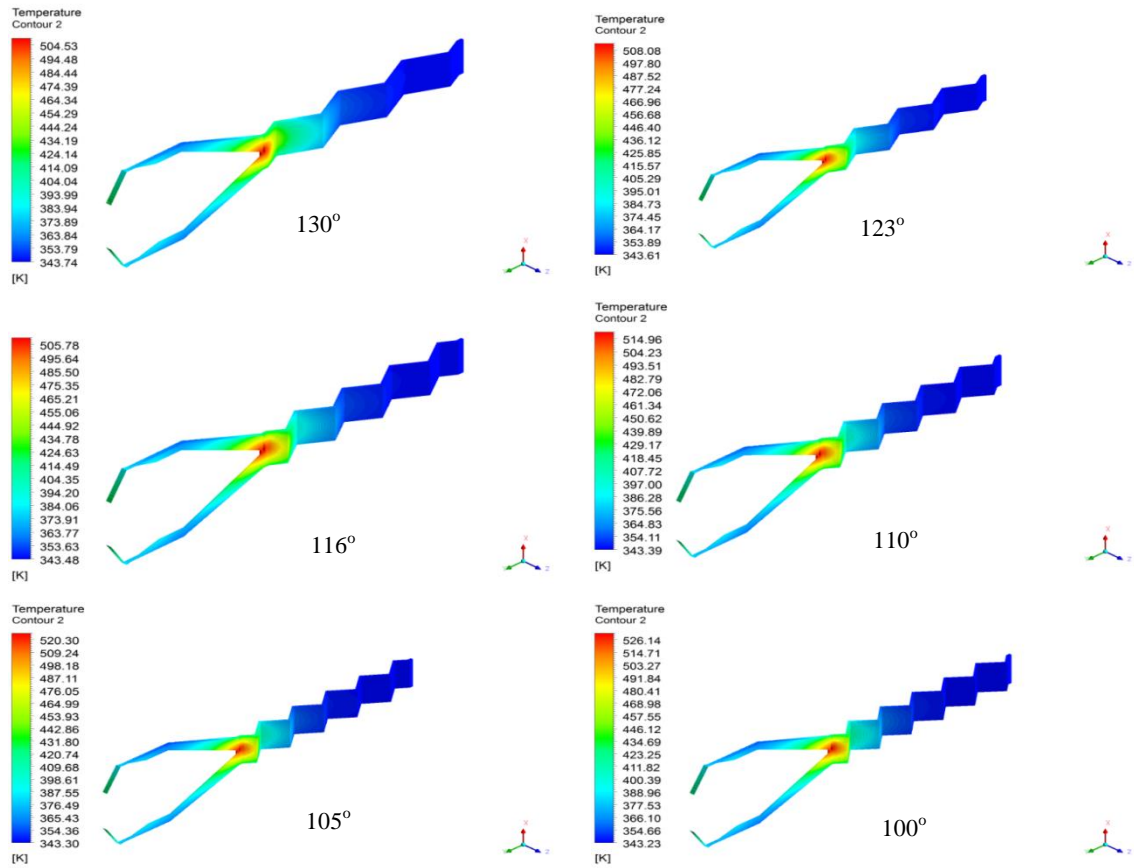

Figure 11. The temperature distributions for zigzag fin profiles at different wave angles

The variation of the pressure drop due versus wave angle is given in Fig.12. The figure indicates that the zigzag (R0 fin profile produces the highest pressure drop. The pressure drop decreases with increasing wave radius. On the other hand, the pressure drop decreases with increasing wave angle for all wave radius. It can be expressed that the variation of the wave angle, especially at the zigzag fin profile, is highly effective on the pressure drop.

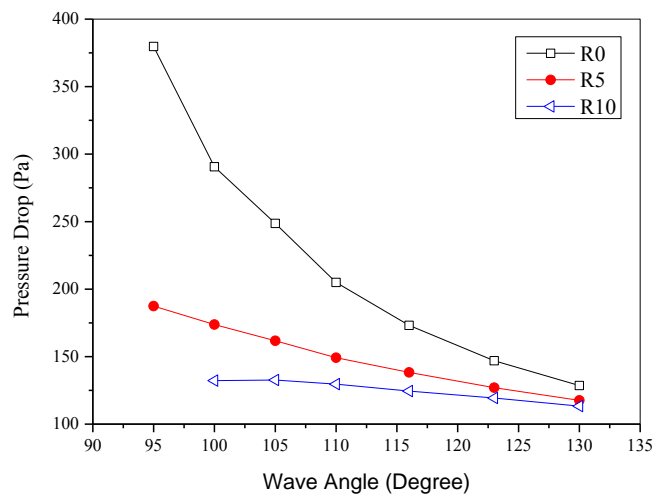

Figure 12. Variation of the pressure drop with wave angle for different wave radius

The effect of wave angle on the amount of heat transferred to the water is shown in Fig.13. As expected, the rate of heat transfer decreases with increasing wave angle and wave radius. The decreases in the heat transfer were calculated as 0.23% and 0.16% for the wave angles of 100° and 130° respectively compared to the flat fin profile.

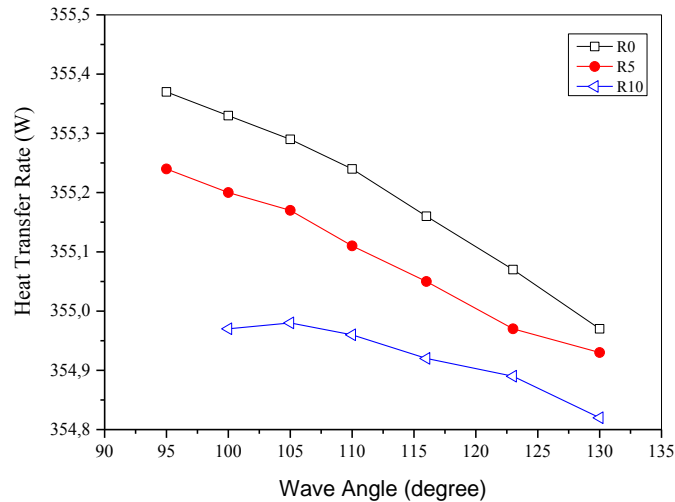

Figure 13. The heat transfer rate to the water with wave angle for different wave radius

4. Conclusions

In the present paper, the thermal performance of a heat exchanger of a combi device was numerically investigated. The heat transfer and pressure drop values for the wavy fins were calculated for different fin profiles. The results obtained in the study are summarized as follows.

The use of wavy fins has reduced the combustion gas outlet temperature, which is an important parameter in combi-devices. In the flat fin profile, the waste gases leaves the heat exchanger at 349.4 K. However, minimum outlet temperature of the waste gas was 343.4 K in zigzag fin profile with 95° wave angle.

The use of wavy fin causes a significant increase in the pressure drop. The highest pressure drop was obtained in zigzag fin with a 95° wave angle as 379.7 Pa, while the lowest pressure drop was obtained with a 130° wave angle and a 15 mm wave radius as 109.3 kPa.

The maximum increase in the rate of heat transferred to the water was calculated as 355.4 W for the zigzag fin profile with 95° wave angle. On the other hand, the lowest value was obtained as 354.8 W for the fin with 134° wave angle and 15 mm wave radius.

The results aforementioned here are for a pair of fins. Consequently, the total gain achieved by using multiple fins in the heat exchangers used in the combi boilers will increase proportionally with the number of fins.

Nomenclature

h Specific enthalpy (kJ/kg), heat convection coefficient [$\text{Wm}^{-2}\text{K}^{-1}$]

h_f	Formation enthalpy [kJkg ⁻¹]
N_p	Mole number of products [kmol]
N_r	Mole number of reaktans [kmol]
P	Pressure [Pa]
R	Wave radius [mm]
θ	Wave angle [deg]

References

- [1] Benim, A.C., Cagan, M. and Gunes, D., Computational Analysis Of Transient Heat Transfer In Turbulent Pipe Flow, *Int. J. Therm. Sci.*, 43 (2004), 8 SPEC. ISS., pp. 725–732
- [2] Benim, A.C., Ozkan, K., Cagan, M. and Gunes, D., Computational Investigation Of Turbulent Jet Impinging Onto Rotating Disc, *Int. J. Numer. Methods Heat&Fluid Flow*, 17 (2007), 3, pp. 284–301
- [3] Chattopadhyay, H., Benim, A.C., Turbulent Heat Transfer Over A Moving Surface Due To Impinging Slot Jets, *J. Heat Transfer*, 133 (2011), 10, Article number:104502, 5 pages
- [4] Benim, A.C., Chattopadhyay, H. and Nahavandi, A., Computational Analysis Of Turbulent Forced Convection In A Channel With A Triangular Prism, *Int. J. Therm. Sci.*, 50 (2011), 10, pp. 1973–1983
- [5] Bhattacharyya, S., Chattopadhyay, H. and Benim, A.C., Simulation Of Heat Transfer Enhancement In Tube Flow With Twisted Tape Insert, *Prog. Comput. Fluid Dyn.*, 17 (2017), 3, pp. 193–197
- [6] Oclon, P., Lopata, S., Nowak, M. and Benim, A.C., Numerical Study On The Effect Of Inner Tube Fouling On The Thermal Performance Of High-temperature Fin-and-tube Heat Exchanger, *Progress Comput. Fluid Dyn.*, 15 (2015), 5, pp. 290–306
- [7] Wang, C.C., Fu, W.L. and Chang, C.T., Heat Transfer And Friction Characteristics Of Typical Wavy Fin-and-tube Heat Exchangers, *Exp. Therm. Fluid Sci.*, 14 (1997), 2, pp. 174–186
- [8] Jang, J., Chen, L., Numerical Analysis Of Heat Transfer And Fluid Flow In A Three-dimensional Wavy-fin And Tube Heat Exchanger, *Int. J. Heat Mass Transf.*, 40 (1997), 16, pp. 3981–3990
- [9] Tao, Y.B., He, Y.L., Huang, J., Wu, Z.G. and Tao, W.Q., Numerical Study Of Local Heat Transfer Coefficient And Fin Efficiency Of Wavy Fin-and-tube Heat Exchangers, *Int. J. Therm. Sci.*, 46 (2007), 8, pp. 768–778
- [10] Junqi, D., Jiangping, C., Zhijiu, C., Yimin, Z. and Wenfeng, Z., Heat Transfer And Pressure Drop Correlations For The Wavy Fin And Flat Tube Heat Exchangers, *Appl. Therm. Eng.*, 27 (2007), 11–12, pp. 2066–2073
- [11] Pourahmad, S., Pesteei, S.M., Effectiveness-NTU Analyses In A Double Tube Heat Exchanger Equipped With Wavy Strip Considering Various Angles, *Energy Convers. Manag.*, 123 (2016), pp. 462–469

- [12] Sakr, M., Convective Heat Transfer And Pressure Drop In V-corrugated Channel With Different Phase Shifts, *Heat Mass Transf.*, 51 (2015), 1, pp. 129–141
- [13] Wang, J., Gao, X., and Li, W., Flow And Heat Transfer Characteristics In A Channel Having Furrowed Wall Based On Sinusoidal Wave, *Korean J. Chem. Eng.*, 32 (2015), 11, pp. 2187–2203
- [14] Rashidi, M.M., Hosseini, A., Pop, I., Kumar, S. and Freidoonimehr, N., Comparative Numerical Study Of Single And Two-phase Models Of Nanofluid Heat Transfer In Wavy Channel, *Appl. Math. Mech. (English Ed.)*, 35 (2014), 7, pp. 831–848
- [15] Goyal, R., Bhargava, R., EFGM Simulation Of Pulsating Doublediffusive Effect On Transpiration Cooling In Nanofluid Filled Wavy Channel, *Int. J. Appl. Comput. Math.*, 3 (2017), 3, pp. 1847–1860
- [16] Singh, N., Sivan, R., Sotoa, M., Faizal, M. and Ahmed, M.R., Experimental Studies On Parallel Wavy Channel Heat Exchangers With Varying Channel Inclination Angles, *Exp. Therm. Fluid Sci.*, 75 (2016), pp. 173–182
- [17] Bahaidarah, H.M.S., Sahin, A.Z., Thermodynamic Analysis Of Fluid Flow In Channels With Wavy Sinusoidal Walls, *Therm. Sci.*, 17 (2013), 3, pp. 813–822
- [18] Gui, X., Song, X., Li, T. and Tang, D., Analysis On Three-Dimensional Flow And Heat Transfer In A Cross Wavy Primary Surface Recuperator For A Microturbine System, *Therm. Sci.*, 19 (2015), 2, pp. 489–496
- [19] Gülcan, Ö.E., Numerical Analysis of Heat Exchanger Used in Combi Boilers, Postgraduate thesis, Sakarya University, Sakarya, Turkey, 2015
- [20] Ansys, I., ANSYS FLUENT Theory Guide, *Knowl. Creat. Diffus. Util.*, 15317 (2009), November, pp. 724–746
- [21] Cengel, Y.A., *Heat And Mass Transfer: A Practical Approach*, 2006