

STUDY ON KEY TECHNOLOGIES OF ENERGY-SAVING AND ENVIRONMENT-PROTECTIVE PUMPS

by

**Qi-Hua ZHANG^{a*}, Yan XU^a, Yuan-Hui XU^a, Wei-Dong SHI^a,
Wei-Gang LU^a, and Wei LIU^b**

^a Research Center of Fluid Machinery Engineering and Technology,
Jiangsu University, Zhenjiang, China

^b Taizhou Jiadi Pump Co., Ltd., Wenling, China

Short paper
DOI: 10.2298/TSCI1305556Z

To meet energy-saving and environment-protective purpose, a series of plastic pumps are developed by composite molding. There are four key techniques involved, firstly, plastic hydraulic components with light-weight; secondly, steel barrel as a pump casing and a connection component as well; thirdly, floating impeller strategy where impeller is drifting freely along shaft; and lastly, a self balancing impeller technique which can totally keep axial force balancing. The manufacturing process is energy-saving, and the components can be recycled, which have great potentials for conservation of environment.

Key words: submersible pump, composite molding, environment-protective, hydraulic

Introduction

Composite materials have been widely used in automobile and electronics industries, where slim and light-weight products are quite popular in modern society. Inherently, plastics are anti-corrosive, recyclable, and relative inexpensive. So it features as energy-saving and environment-protective, which is very promising to be further introduced into submersible pump manufacturing industry. Therefore, it is especially important to enhance innovation of key techniques involved in manufacturing these plastic pumps.

A multistage submersible pump was developed which was much compact and efficient [1, 2]. However, steel casting was adopted to mold its major components. Therefore, the pump is so bulky and costly that its popularity is hindered. To tackle this problem, composite molding was adopted in impeller manufacturing [3], and plastics were used in manufacturing of guide vane [4]. To examine structural steadiness of multistage submersible pumps, axial force imposed on submersible multistage pump was further conducted numerically and experimentally [5]. Recently, unsteady flow induced pressure pulsation of multistage submersible pump was conducted numerically [6], and a hydraulic design system for plastic guide vanes was developed in [7].

Structural design

As shown in fig. 1, a single stage is consisted of such components as steel barrel, impeller, and guide vane. The impeller and guide vane are made by composite molding. The barrel is made by stainless steel which supports the impeller and connects the guide vane. These components constitute a compact stage.

* Corresponding author; e-mail: qhzhang@ujs.edu.cn

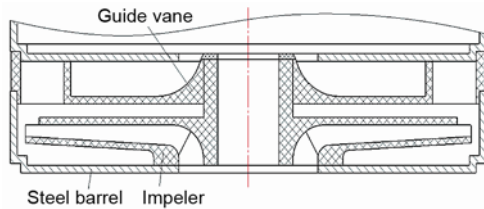

Figure 1. Schematic of a single stage

front end face and barrel inner surface is enlarged, and leaking flow is increased which rapidly decreases pressure within front barrel cavity. Subsequently, impeller will dynamically float downward along its shaft. It is noticed that a plastic impeller and a steel barrel forms a natural pair of seal, which is especially effective under water lubrication. Meanwhile, a plastic impeller and a steel barrel is also a natural frictional pair. During transient period of pump starting and stopping, the plastic impeller front end face will be grinded by the steel barrel, but its wear is negligibly small under wet condition.

Self balancing impeller

Commonly, impeller is consisted by shroud plate, blades, and hub plate. As depicted in fig. 2(a), a parabolic distribution of pressure is imposed on impeller. According to calculation [8], a residual force is always toward impeller suction. Therefore, the pressure imposed on hub plate must be reduced. As shown in fig. 2(b), the outer edge of impeller hub plate is cut by a small ratio, *i. e.*, 5%. Subsequently, hydraulic pressure exerted on hub plate will be decreased correspondingly.

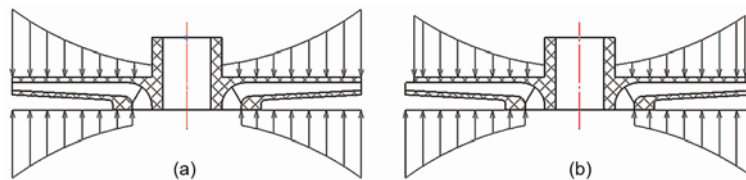

Figure 2. Pressure distribution; (a) unbalanced pressure distribution, (b) balanced pressure distribution

The advantage of cutting outer wheel is that its axial force can be reduced. Meanwhile, incorporating the floating impeller technique, this axial force can be minimized. This minor residual force transmitted to bearing of motor is negligible. Therefore, this means can entirely keep impeller self balancing. Another advantage is that its discharge flow area is enlarged and its through flow performance can be improved.

Hydraulic design

Impeller design

As foregoing analysis, adopting composite molding requires that molding components must be ease of parting. Thus cylindrical blade is preferable in this situation. A set of design parameters for a small to medium specific speed pump is considered. Its flow rate is $Q = 2 \text{ m}^3/\text{h}$, head is $H = 4 \text{ m}$, and rotating speed is $n = 2850 \text{ rpm}$. Its specific speed is 86.7. An

error-triangle method is adopted in development of a cylindrical impeller. Its design procedure is omitted here for simplicity. The key parameters are listed in tab. 1.

Table 1. Impeller parameters

Z	D_j [mm]	D_h [mm]	D_2 [mm]	D_{20} [mm]	b_2 [mm]	β_1 [°]	β_2 [°]	φ [°]
7	24	17.5	80	76	1.8	37	26	120

With these geometrical parameters, the impeller is designed as cylindrical shape, as shown in fig. 3.

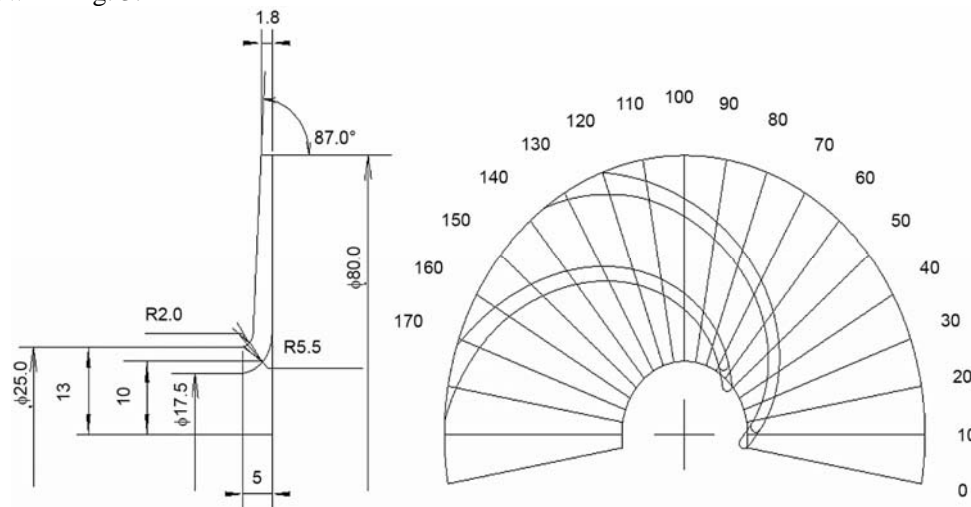

Figure 3. Drawing of impeller

Guide vane design

A design system has been intensely used in development of guide vanes [8]. The major parameters of guide vane are listed in tab. 2.

Table 2. Guide vane parameters

Z	D_3 [mm]	D_4 [mm]	b_2 [mm]	β_3 [°]	β_4 [°]	φ [°]
6	85	23	5.5	14.5	85	110

With above geometrical parameters, the drawing of guide vane is plotted in fig. 4.

Series production

A longstanding investigation of key techniques of manufacturing plastic multistage pumps has been conducted at Jiangsu University and Jiadi Pump Co., Ltd.

The achievements on plastic pumps have formed series productions. Some samples are shown in fig. 5.

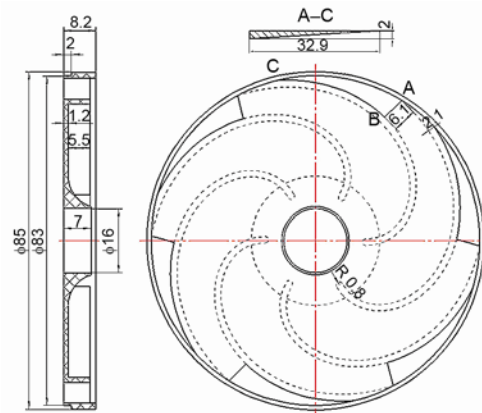

Figure 4. Structure and dimensions of guide vane

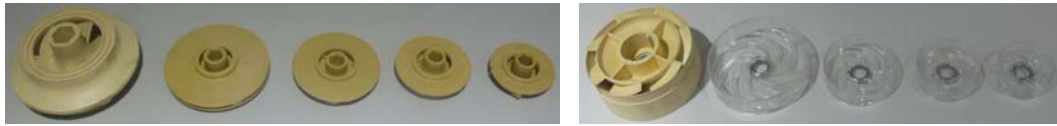

Figure 5. Sample plastic impellers and guide vanes

Conclusions

To improve independent innovation, a set of strategies for development of submersible multistage plastic pumps are developed. A steel barrel is used to setup a single stage, where hydraulic components such as impeller and guide vane are made of plastics. By this means, it leads to a compact structure. Then a floating impeller strategy is used to balancing hydraulic pressure on impeller, which could effectively reduce residual force and make the pump's operation more stable. These strategies have been utilized to develop a series of plastic pumps.

Acknowledgment

The authors would like to thank the National Natural Science Foundation of China (No. 51309118), the National Natural Science Foundation of Jiangsu Province (No. BK20130527), the Scientific Research Foundation for Senior Talents of Jiangsu University (No. 11JDG085), the Postdoctoral foundation of Jiangsu Province (No. 1102157C), and Post-doctoral Science foundation of China (No. 2013M531282)

References

- [1] Shi, W. D., *et al.*, Hydraulic Design of New-Type Deep Well Pump and Its Flow Calculation, *J. Jiangsu University (Natural Science Edition)*, 27 (2006), 6, pp. 528-531
- [2] Roclawski, H., Hellmann, D. H., Rotor-Stator-Interaction of a Radial Centrifugal Pump Stage with Minimum Stage Diameter, *Proceedings, 4th WSEAS International Conference on Fluid Mechanics and Aerodynamics*, Elounda, Greece, 2006, pp. 301-308
- [3] Wang, H. L., *et al.*, Optimization Design of Deep Well Pump Based on Latin Square Test, *Transactions of the Chinese Society for Agricultural Machinery*, 41 (2010), 5, pp. 56-63
- [4] Zhou, L., *et al.*, Performance Analysis on Deep-Well Centrifugal Pump Guide Vanes Based on Numerical Simulation. *Transactions of the Chinese Society of Agricultural Engineering*, 27 (2011), 9, pp. 38-42
- [5] Zhou, L., *et al.*, Numerical Prediction and Experiment of Axial Force on Deep-Well Centrifugal Pump, *Transactions of the Chinese Society for Agricultural Machinery*, 43 (2012), 7, pp. 100-103
- [6] Shi, W. D., *et al.*, Analysis on Pressure Fluctuation of Unsteady Flow in Deep-Well Centrifugal Pump, *Transactions of the Chinese Society of Agricultural Engineering*, 27 (2011), 10, pp. 44-49
- [7] Zhang, Q. H., *et al.*, Research and Development on the Hydraulic Design System of the Guide Vanes of Deep-Well Pumps, *Applied Mechanics and Materials*, 197 (2012), pp. 24-30
- [8] Guan, X. F., *Modern Pumps Theory and Design*, China Astronautic Publishing House, Beijing, China, 2011